

**N.B.K.R INSTITUTE OF SCIENCE AND TECHNOLOGY**

**VIDYANAGAR, A.P - 524413**



# **ELECTRICAL WORKSHOP**

**Skill Oriented Course Manual**



**DEPARTMENT OF  
ELECTRICAL AND ELECTRONICS ENGINEERING**

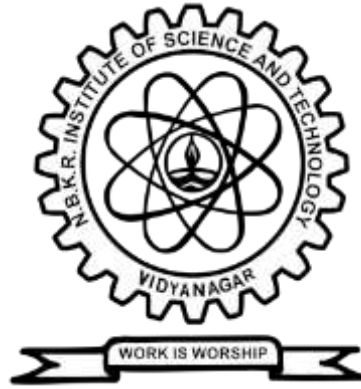

**N.B.K.R INSTITUTE OF SCIENCE AND TECHNOLOGY  
(AUTONOMOUS)  
VIDYANAGAR**

**CERTIFICATE**

This is to certify the record of Bonafide work done in  
Electrical Workshop Skill Oriented Course (20EE21S1) By  
Mr./Ms. \_\_\_\_\_ of  
Roll No. \_\_\_\_\_ during the  
Academic Year \_\_\_\_\_.

Signature of In charge

Signature of Examiner

## **Electrical Workshop - Skill oriented (Theory & Practical) - Syllabus**

### **UNIT – I**

**Electrical Tools, Instruments and Electrical Symbols:** Introduction of Different types of Electrical tools, Instruments and explain their function. Different types of electrical symbols.

**Experiments:**

Physical Demonstration of usage of different types of electrical tools & Instruments.

**Personal Protective Equipment:** Hierarchy of controls as it relates to personal protective equipment. Different types of personal protective equipment utilized in general industry. Personal protective equipment training requirements.

**Experiments:**

Physical Demonstration of usage of different types of PPE.

### **UNIT – II**

**House wiring 1:** House wiring materials and their selection, House wiring

**Experiments:**

1. Control a Light Bulb by a Single Way or One-way Switch
2. Switch board containing at least two switches, one fan regulator and one 5A plug point
3. Staircase wiring and Go-down Wiring
4. Fluorescent Tube Light

### **UNIT-III**

**House wiring 2:** Wiring for different equipments

**Experiments:**

5. Residential House Wiring Using Fuse, Switch, Indicator, Lamp and Energy Meter.
6. Ceiling Fan Connection with Regulator, Switch and Capacitor.
7. Inverter connection diagram. Install Inverter and Battery at Home.

### **UNIT – IV**

**Electrical Safety:** Static Electrical safety rules, Electrical Shock –causes for electric shock, Preventive measures to electric shock, Earthing.

**Experiments:**

1. Demonstration of CPR
2. Earthing demonstration and field visit
3. Measurement of earth resistance

### **UNIT – V**

**House hold Electrical appliances:** Dismantling and assembling of different electrical appliances (steam iron box, electric geyser, Table fan and Ceiling fan).

**Experiments:**

1. Dismantling and assembling of steam iron box
2. Dismantling and assembling of an electric geyser
3. Dismantling and assembling of Table fan
4. Dismantling and assembling of Ceiling fan

### **UNIT –VI**

**Batteries and their applications:** Different types of batteries and their applications, Working of lead acid battery, Charging of the battery.

**Experiments:**

1. Physical demonstration of battery
2. Testing of lead acid battery
3. Charging of lead acid battery

**ELECTRICAL WORKSHOP (SKILL ORIENTED COURSE)**  
**LABORATORY CLASSES: DO'S AND DON'T'S FOR STUDENTS**

**DO'S**

1. Come in shoes and tight-fitting dress with shirts tucked inside.
2. Girl students should put up their hair also.
3. Observation book should be maintained neatly, and should contain aims, circuit diagrams, tabular columns, and design, if any, of all the experiments done by the students.
4. Come well prepared about the experiment (both theory and procedure) to any, of all the experiments done by the students.
5. While coming to the laboratory classes, bring the required items such as calculator, graph sheets, tools, pen, pencil, eraser etc. along with the observation book in which the details, mentioned above, of the experiment to be done on that day, are entered neatly.
6. Show and get the circuit diagrams and other details verified and approved by the lab-in-charge before doing the experiment.
7. Borrow the meters/components for the experiment through an indent signed by the lab-in-charge, complete the connections as per the approved diagrams and get it checked by the staff-in-charge.
8. Get the respective main switch ON by the laboratory staff.
9. Prepare the report of the experiment done and submit in time.
10. Return the items borrowed and get a clearance to leave the laboratory.

**DONT'S**

1. Don't wear long chains.
2. Don't sit on the tables.
3. Don't try to switch on the mains on any account.
4. Don't energize the circuit without the permission of the staff in charge.
5. Don't forget the fact that the terminals on the table are live during the course of the experiment.

## ELECTRICAL WORKSHOP (SKILL ORIENTED COURSE)

### Unit-1

(9 Hours)

#### Electrical Tools, Instruments and Electrical Symbols

Introduction of

- Different types of electrical tools & instruments and their function
- Different types of electrical symbols

#### Experiments

Physical demonstration of usage of different types of electrical tools & instruments.

#### Personal Protective Equipment (PPE)

- Hierarchy of controls as it relates to personal protective equipment
- Different types of personal protective equipment utilized in general industry
- Personal protective equipment training requirements

#### Experiments:

Physical demonstration about usage of different types of PPE.

#### Introduction of tools, electrical instruments, symbols

#### TOOLS:

**PLIER:** Generally three types of pliers are used in the electrical workshop. They are:-



(i) **FLAT NOSE PLIER:** Used for holding jobs or holding wires. It has got only two slotted jaws, which are tapered. Thus it is used for tightening or loosening small nuts.



(ii) **SIDE CUTTING PLIER:** Used for cutting of thin wires and removing insulations from them. It has got cutting edge on its one of its sides.



**(iii) ROUND NOSE PLIER:** Used only to hold or cut the wires. It has no gripping jaws. Its cutting edge is long and rounded on the top.



**SCREW DRIVER:** It is used to loosen or tighten or to keep screws in position. It has a wooden or plastic handle and a blade of high carbon steel.



**CHISEL:**

**(i) FIRMER CHISEL:** Generally used for carpentry works and can be used by hand pressure or with the help of mallet. It has flat blade, which varies from 12mm to 15mm.



(ii) **COLD CHISEL:** Used for cutting iron pieces (cold). It has cutting angle from  $30^{\circ}$  to  $45^{\circ}$  and is made of high carbon steel.



**HAMMER:** Most commonly used in the workshop. The head is made of cast iron or forged; the claw is hardened and tempered. The striking place is slightly convex. The head is fitted with a wooden handle of various lengths.



**HACKSAW:** Used to cut metal such as iron strips, core pipes etc. it has a blade made of high steel or tungsten.

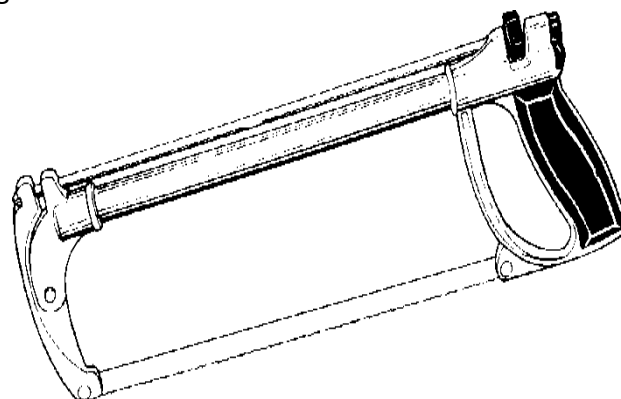

## DOUBLE ENDED SPANNER

Used to tighten and loosen bolts, nuts and screw etc.



## ELECTRICAL INSTRUMENTS:



Name	Purpose
Ammeter (Ampere meter)	Measures current
Capacitance meter	Measures the capacitance of a component
Cos Phi Meter	Measures the power factor
Frequency counter	Measures the frequency of the current
LCR meter	Measures the inductance, capacitance and resistance of a component
Megger– Resistance tester	Measures resistance of an winding of motor or generator and measures earthing resistance
Megger–Insulation Resistance tester	Measures insulation resistance of an winding of motor, generator, transformer etc.
Multimeter	General purpose instrument measures voltage, current and resistance (and sometimes other quantities as well)
Ohmmeter	Measures the resistance of a component



Name	Purpose
Oscilloscope	Displays waveform of a signal, allows measurement of frequency, timing, peak excursion, offset, ...
Tachometer	Measures speed of motors
Signal generator	Generates signals for testing purposes
Wattmeter	Measures power in a circuit
Voltmeter	Measures the potential difference between two points in a circuit.

**EARTH (GROUND) TESTER:**

The instrument used for measuring the resistance of the earth is known as earth tester. All the equipment of the power system is connected to the earth through the earth electrode. The earth protects the equipment and personnel from the fault current.



**INSULATION TESTER:**

The Megger insulation tester is a small, portable instrument that gives you a direct reading of insulation resistance in ohms or mega ohms. The Megger insulation tester is essentially a high-range resistance meter (ohmmeter) with a built-in direct-current generator.



## **ABBREVIATIONS:**

<b>S.NO.</b>	<b>NAME OF THE UNIT</b>	<b>ABBREVIATION</b>
1.	VOLTS	V
2.	AMPERES	Amp
3.	LOW TENSION	LT
4.	HIGH TENSION	HT
5.	OIL CIRCUIT BREAKER	OCB
6.	KILO-VOLTS	KV
7.	MAIN SWITCH	MS
8.	SUB-MAIN SWITCH	SMS
9.	DISTRIBUTION BOARD	DB
10.	IRON CLAD DISTRIBUTION BOARD	ICDB
11.	CONTROL BOARD	CB
12.	SWITCH BOARD	SB
13.	NORMALLY OPEN	NO
14.	NORMALLY CLOSED	NC
15.	TIME DELAY RELAY	TDR
16.	NO VOLT RELEASE	NVR
17.	SUB-DISTRIBUTION BOARD	SDB
18.	OVER LOAD RELEASE	OLR
19.	DIRECT ON LINE	DOL
20.	DOUBLE POLE IRON CLAD	DPIC

21.	ALL ALLUMINIUM CONDUCTOR	AAC
22.	ALTERNATING CURRENT	AC
23.	DIRECT CURRENT	DC
24.	TRIPLE POLE IRON CLAD	TPIC
25.	AIR CIRCUIT BREAKER	ACB
26.	CURRENT TRANSFORMER	CT
27.	CAB TYPE SHEATHED	CTS
28.	CAPACITIVE VOLTAGE TRANSFORMER	CVT
29.	EARTH LEAKAGE CIRCUIT BREAKER	ELCB
30.	EXTRA HIGH VOLTAGE	EHV
31.	ELECTROMOTIVE FORCE	EMF
32.	HIGH RAPTURE CAPACITY FUSE	HRCF
33.	HIGH VOLTAGE	HV
34.	LOW VOLTAGE	LC
35.	KILO VOLT AMPERE	KVA
36.	KILO WATT	KW
37.	KILO WATT HOUR	KWh
38.	LIGHTENING ARRESTER	LA
39.	LIGHT DEPENDENT RESISTANCE	LDR
40.	LOW PRESSURE Hg VAPOUR LAMP	LPMVL
41.	LOW VOLTAGE	LV
42.	LIGHT EMITTING DIODE	LED
43.	MINIATURE CIRCUIT BREAKER	MCB
44.	MEGA WATT	MW

45.	NEUTRAL LINK	NL
46.	OVER LOAD TRIP COIL	OLPEC
47.	PHASE	Ph
48.	POTENTIAL TRANSFORMER	PT
48.	POLYVINYL CHLORIDE	PVC
49.	PAPER INSULATED LEAD COVERED	PILC
50.	SERIES	Se
51.	SHUNT	Sh
52.	SUB MAIN SWITCH	SMS
53.	SINGLE POLE	SP
54.	SINGLE POLE DOUBLE THROW	SPDT
55.	SINGLE POLE SINGLE THROW	SPST
56.	STANDARD WIRE GAUGE	SWG
57.	TRIPLE POLE SWITCH	TPS
58.	SODIUM VAPOUR LAMP	SWL
59.	SODIUM UNILATERAL SWITCH	SUS
60.	TRIPLE POLE WITH NEUTRAL	TPN
61.	TRIPLE POLE IRON CLAD	TPIC
62.	TRIPLE POLE DOUBLE THROW	TPDT
63.	TRIPLE POLE SINGLE THROW	TPST
64.	THERMAL RELAY	TR
65.	TOUGH RUBBER SHEATHED	TRS
66.	VOLT AMPERE	VA
67.	VULCANISED INDIAN RUBBER	VIR
68.	WATER TIGHT	WT
69.	WEATHER-PROOF CABLE	WPC

71.	RESISTANCE	R
72.	CAPACITOR	C
73.	INDUCTANCE	L
74.	BATTERY	E

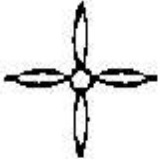

### **QUIZ/ANSWERS**

Q1.	What is the abbreviation of kva?	Kilo Volt Amperes
Q2.	Name the standard of the wires according to their gauges?	1/8, 3/20, 7/20, 7/22
Q3.	What is the use of lamp holder?	Hold in particular position
Q4.	What is the symbol of the ceiling fan?	
Q5.	What is the function of hawk saw?	To cut pipes, metal sheet & wooden pieces
Q6.	How many types of pliers we used?	Flat nose, long nose, cutting & combination
Q7.	What do you meant by RPM?	Revolutions per minute
Q8.	What is the function of chisel?	Cutting metal pieces
Q9.	What is the function of screwdriver?	It is used to loosen or tighten or to keep screws in position
Q10.	Why we use flexible wires?	Increasing the length of the supply cable







### Electrical Wiring Symbols for Wire

Name	Meaning / Function	Symbol
Electrical Wire	Conduct Electricity	
Connected Wires	Wires are Connected	
Not Connected Wires	Wires are not Connected	

### Electrical Wiring Symbols for Ground

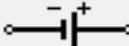

Name	Meaning / Function	Symbol
Earth Ground	Protection against Electrical Shock	
Chassis Ground	Connected to Chassis of a Circuit	
Common Ground	For Analog and Digital Grounding	

### Power Supply Symbols





Name	Meaning / Function	Symbol
Voltage Source	Constant Voltage Source	
Current Source	Constant Current Source	
AC Voltage Source	Source of AC Voltage	
Battery	Constant Voltage Source	
Battery Cell	Constant Voltage Source	
Generator	Mechanical Voltage Source	





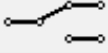
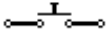
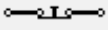

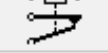
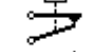
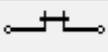



### Lamp and Light Bulb Symbols

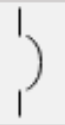





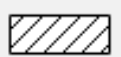

Name	Meaning / Function	Symbol
Lamp or Light Bulb	Generates Light with Flow of Current	
Lamp or Light Bulb	Generates Light with Flow of Current	
Lamp or Light Bulb	Generates Light with Flow of Current	

### Switch and Relay Symbols

Name	Meaning / Function	Symbol
SPST Toggle Switch	Disconnect Current when Open	
SPDT Toggle Switch	Select Between 2 Connections	
Push Button Switch (N.O)	Switch Momentary – Generally Open	
Push Button Switch (N.C)	Switch Momentary – Generally Closed	
DIP Switch	Onboard Configuration	
SPST Relay	Single Pole Single Throw	
SPDT Relay	Single Pole Double Throw	
Jumper	Jumper to Close Connection	
Solder Bridge	Solder Connection	

### Other Important Electrical Wiring Symbols

Name	Meaning / Function	Symbol
Electrical Switch box	Box to Install Switches	
Circuit Breaker	Trip to Break the <b>Electric Circuit</b> and Stop Flow of Electricity	
Dishwasher Outlet	Outlet for Dishwasher	
Fan Outlet	Outlet for Fan	
Junction Box	Install Junction Box	
TV Outlet	Outlet for Television	
Exhaust Fan	Outlet for Exhaust Fan	
Water Heater Outlet	Outlet for Water Heater	
Telephone Jack Outlet	Outlet for Telephone Jack	

Name	Meaning / Function	Symbol
Electrical Panel	Install Electrical Panel	
Distribution Box	Install Distribution Box	
Thermostat	Install Thermostat	
Air Condition	Install Air Condition	
Fire Alarm	Install Fire Alarm	
Alarm	Install Alarm	
Doorbell	Install Doorbell	
Smoke Detector	Install Smoke Detector	



**Write the observations and experiences**

## **PERSONAL PROTECTIVE EQUIPMENT (PPE)**

### **Objectives**

1. Describe the hierarchy of controls as it relates to personal protective equipment.
2. Identify types of personal protective equipment utilized in general industry.
3. Explain personal protective equipment training requirements.

### **Employers must protect employees:**

- Assess the workplace
- Eliminate and reduce the hazards found using engineering and administrative controls
- Then use appropriate personal protective equipment
- Remember, Personal Protective Equipment is the last level of control

### **Hierarchy of Controls:**

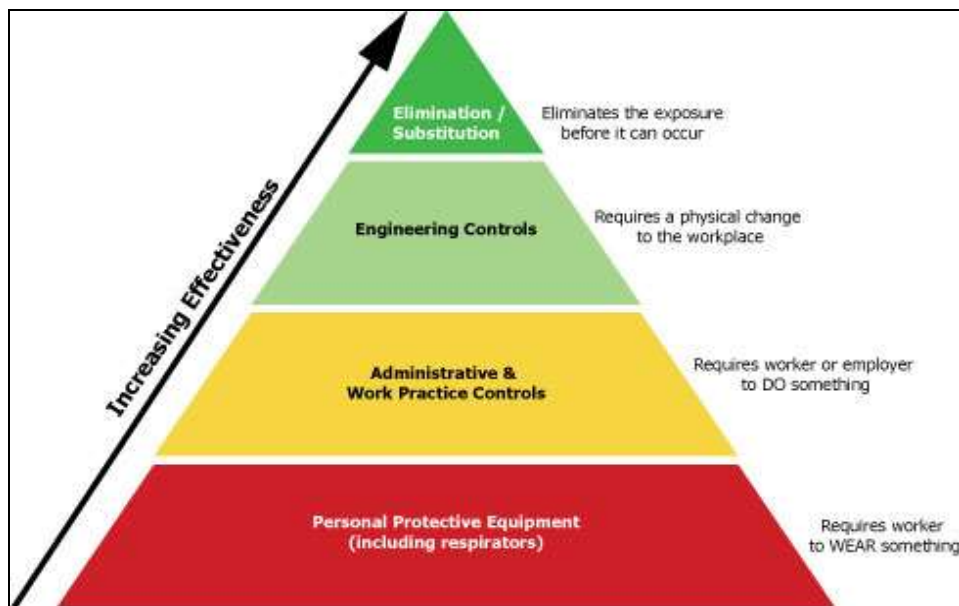

### **Elimination/substitution:**

- Highest level of protection
- Eliminate hazard from the workplace
- Substitute
  - Use safer item/substance
  - Use same chemical but in a different form; as particle size of a substance decreases, hazard level increases

### **Engineering controls:**

- Physical changes to workplace
- Examples
  - Isolation
  - Ventilation
  - Equipment modification
  - Others

### **Administrative controls/work practice control:**

- Requires worker or employer to do something
- Examples
  - Written proper operating procedures, work permits and safe work practices
  - Inspection and maintenance
  - Housekeeping
  - Monitoring the use of highly hazardous materials
  - Supervision and Training
  - Alarms, signs and warnings
  - Regulated areas
  - Limit exposure by time or distance

#### PPE controls:

- Requires worker to wear something
- Examples



#### Head protection

- Frequent causes of head injuries
  - Falling objects from above striking on the head;
  - Bump head against fixed objects, such as exposed pipes or beams; or
 Accidental head contact with electrical hazards.

- **Classes of hard hats:**

- **CLASS G (General)**
  - Protect against impact, penetration
  - Low-voltage electrical protection (proof-tested to 2,200 volts)
- **CLASS E (Electrical)**
  - Designed for electrical/utility work
  - Protect against falling objects, impact
  - Electrical protection against high-voltage (proof-tested to 20,000 volts)
- **CLASS C (Conductive)**



- Designed for comfort; offers limited protection
- Protects heads that may bump against fixed objects
- Does not protect against falling objects or electrical hazards

### Eye and face protection:

- Common causes of eye injuries
  - Chemical splashes
  - Blood or OPIM splashes or sprays
  - Intense light
  - Dust and other flying particles
  - Molten metal splashes
- Selecting eye and face protection – elements to consider:
  - Ability to protect against workplace hazards
  - Should fit properly
  - Should provide unrestricted vision and movement
  - Durable and cleanable
  - Allow unrestricted functioning of other PPE
- Safety glasses
  - Used to protect against moderate impacts from particles

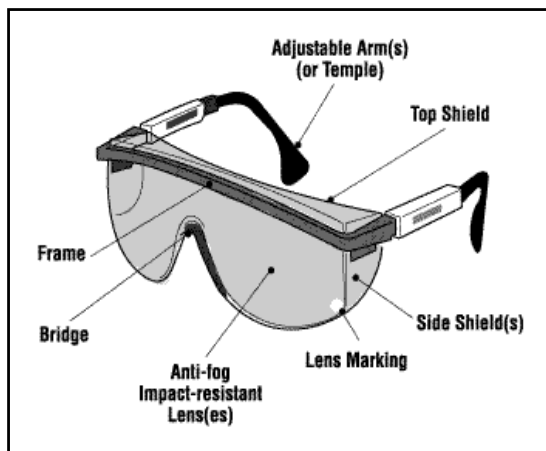

### Goggles

- Protect eyes, and the facial area immediately surrounding the eyes from impact, dust, splashes.
- Some can be used over corrective lenses, if they fit them.



### Goggle types

- **Direct-ventilated**
  - Resist direct passage of large particles into the goggle
  - Prevents fogging by allowing air circulation

– **Indirect-ventilated**

- Prevents fogging by allowing air circulation
- Protects against liquid or chemical splash entry



– **Non-ventilated**

- Does not allow the passage of air into the goggle
- Prevents splash entry
- May fog and require frequent lens cleaning

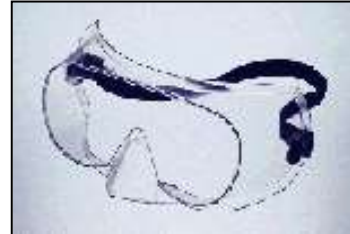

– **Face shields**

- Protect face from nuisance dusts and potential splashes or sprays of hazardous liquids
- Shields do not protect from impact hazards unless so rated
- Shields are for face protection, not eye protection. To protect the eyes, wear safety glasses with side shields, or goggles under the face shield.



– **Welding shields**

- Protect eyes from burns caused by:
  - ✓ Infrared light
  - ✓ Intense radiant light
- Protect eyes and face from flying sparks, metal spatter, and slag chips



– **Laser safety goggles**

- Provide protection from hazards:
  - physical contact such as flying particles
  - ultraviolet light, laser, and welding



## Hearing protection:

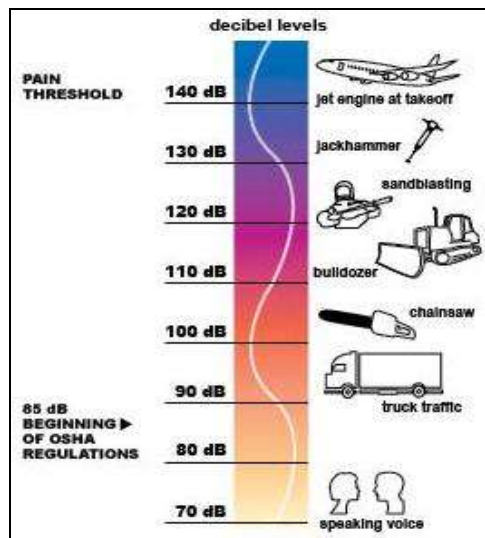

- Exposure to noise levels over 85 dB can cause hearing loss
- Hearing protection required at 90 dB Implement effective hearing conservation program
- The employer must provide ear protection when the noise level in the work area is greater than indicated in this table.

Permissible Noise Exposure 29 CFR 1910.95(b)(1)	
Duration per Day (hours)	Sound Level (dBA)
8	90
6	92
4	95
3	97
2	100
1	105
½	110
¼	115

- Examples of hearing protection:
  - Disposable foam plugs
  - Molded ear plugs
  - Noise-cancelling ear plugs
  - Ear muffs
- Consider Noise Reduction Rating (NRR) of devices



## Hand protection:

- Potential hazards for hands



- Skin absorption of hazardous substances
- Lacerations or severe cuts
- Punctures
- Chemical burns
- Thermal burns
- Extreme temperatures
- Types of gloves



Anti-vibration



Chemical-Resistant



Leather Palm



Permeation-resistant



Heat-resistant



Cut-resistant

**Foot and leg protection:**

- Causes of foot injuries:
  - Falling or rolling of heavy objects
  - Crushing or penetrating materials
  - Sharp objects that can penetrate the sole
  - Exposure to molten metal
  - Working on, or around, hot, wet, or slippery surfaces
  - Working when electrical hazards are present.
- Conditions requiring foot protection
  - Impacts
  - Compressions
  - Cuts/punctures



- Chemicals
- Temperatures

- Examples of foot and leg protection
  - Impact-resistant toe and/or instep
    - Steel
    - Composite
  - Heat-resistant soles
  - Metal shanks
  - Specialty footwear may be needed
    - Metatarsal guards
    - Liquid- or chemical-resistant
    - Conductive or nonconductive



- Protection from hazards
  - Shoes with metal toe-cap protects against knocks, falling objects
  - Rubber shoes protect against chemical materials, as directed by the SDS



**Body protection – protective clothing:**





- Provide protective clothing for those parts of the body exposed to possible injuries
- Types of body protection
  - Laboratory coats
  - Coveralls
  - Vests
  - Jackets
  - Aprons
  - Surgical gowns
  - Full-body suits



- Selection of body protection – variety of materials effective against particular hazard
  - Paper-like fiber – dust and splashes
  - Treated wool and cotton – fire-resistant; dust, abrasions, rough/irritating surfaces
  - Duck – cuts, bruises
  - Leather – dry heat, flames
  - Rubber, rubberized fabrics, neoprene, and plastics – certain chemicals and physical hazards



- **Environmental Protection Agency's (EPA) levels of PPE**

- **Level A**

- Provides highest level of protection
- Required when greatest potential for exposure exists and greatest level of skin, respiratory, and eye protection is required
- Examples
  - Positive pressure, full face piece Self Controlled Breathing Apparatus (SCBA), or positive pressure supplied air respirator with escape SCBA
  - Totally encapsulated chemical- and vapor-protective suit
  - Inner and outer chemical-resistant gloves
  - Disposable protective suit, gloves, and boots

- **Level B**

- Required for highest level of respiratory protection and lesser level of skin protection
- Examples
  - Positive pressure, full face piece SCBA, or positive pressure supplied air respirator with escape SCBA
  - Inner and outer chemical-resistant gloves
  - Face shield
  - Hooded chemical-resistant clothing
  - Outer chemical-resistant boots
  - Coveralls

- **Level C**
  - Required when concentration and type of airborne substances are known and criteria for using APR is met
  - Examples
    - Full-face air-purifying respirators
    - Inner and outer chemical-resistant gloves
    - Hard hat
    - Escape mask
    - Disposable chemical-resistant outer boots
- **Level D**
  - Required when minimum protection is needed
  - Sufficient when no contaminants are present or work operations preclude splashes, immersion, or potential for unexpected inhalation or contact
  - Examples
    - Gloves
    - Coveralls
    - Safety glasses
    - Face shield
    - Chemical-resistant, steel-toe boots or shoes

### **Training**

Training requirements:

- Each employee who is required to use PPE must be trained to know:
  - When PPE is necessary
  - What PPE is necessary
  - How to properly put on, take off, adjust, and wear the PPE
  - The limitation of the PPE
  - Proper care, maintenance, useful life, and disposal of PPE

### **Responsibilities**

- The **employer** is required to:
  - Perform hazard assessment
  - Provide appropriate PPE
  - Train employees
  - Maintain/replace PPE
  - Review/update/evaluate PPE Program
- The **employee** is required to:
  - Properly wear PPE
  - Attend PPE training
  - Care for, clean, and maintain PPE
  - Inform supervisor of needs for repair/replacement

### Knowledge Check

1. Common causes of foot injuries include: crushing, penetration, molten metal, chemicals, slippery surfaces, and sharp objects.  
a. True                                      b. False

**Answer: a. True**

2. Who is responsible for providing PPE needed to comply with OSHA standards?  
a. The employee                              b. OSHA  
c. The Employer                              d. Workers' Compensation

**Answer: c. The Employer**

3. Hazard controls must be addressed in which order of priority?  
a. Substitution, PPE, workaround, and administrative  
b. Workaround, stop work, PPE, and engineering  
c. Stop work, PPE, engineering, and substitution  
d. Substitution, engineering, administrative, and PPE

**Answer: d. Substitution, engineering, administrative, and PPE**

4. Which type of hard hat would provide the most protection from electrical hazards?  
a. Class A                              b. Class C                              c. Class E                              d. Class G

**Answer: c. Class E**

5. Hearing protection is required when noise levels exceed OSHA's PEL of \_\_\_ dBA as a TWA.  
a. 80                              b. 90                              c. 100                              d. 110

**Answer: b. 90 dBAs**

6. Who is responsible for providing specialized work footwear?  
a. Insurance companies                              b. The employee  
c. OSHA    d. The employer

**Answer: d. The employer**

7. Which of the following is considered approved eye protection?  
a. Sun glasses  
b. Prescription glasses  
c. Reading glasses  
d. Glasses meeting ANSI standard Z87

**Answer: d. Glasses meeting ANSI standard Z87**

8. Which of the following is **NOT** considered PPE?  
a. Rubber gloves  
b. Glasses meeting ANSI standard Z87  
c. Sports shoes  
d. Hearing muffs

**Answer: c. Sports shoes**

**Write the observations and experiences**

**House wiring 1:**

House wiring materials and their selection

House wiring

Experiments:

1. Control a light bulb by a single way or one-way switch
2. Switch board containing at least two switches, one fan regulator and one 5A plug point
3. Staircase wiring and Godown Wiring
4. Fluorescent tube light

**HOUSE WIRING MATERIALS:**

- **TUMBLER SWITCH:** (6 A for light), this switch was used 3-4 decade ago. It is made of bakelite.



- **MCB BOX:** Known as the miniature circuit breaker box.



**METAL CONDUIT PIPE WITH JUNCTION BOX:** Metallic hollow pipe, which is used as a passage for electrical house, hold wires. It is fixed to walls with the help of metallic saddle.



**METAL BEND:** Hollow metallic pipe bend to an angle of 90° to allow smooth movement of wires inserted through the walls during wiring.

**BATTEN WIRING:** It is an old fashioned wiring used 4-5 decades ago.



**PVC CASING AND CAPPING:** Long rectangular box made of 2 parts. It is made of PVC and used mainly to pass wires through walls during wiring.



**PVC CONDUIT, BEND AND JUNCTION BOX:** Similarly as metal conduit, bend and junction boxes but it is made up of PVC that makes it lighter, cheaper and more durable and also used in concealed wiring.



**BATTEN LAMP HOLDER:** mainly used to hold electric bulbs and lamps.



**SWITCH BOARD WITH SWITCHES:** it contains the following:



**SOCKET OUTLETS:** it is a type of electrical material through which electric current flows from wires to various electrical appliances. It is of 6A.

**TWO WAY SWITCH:** it is mainly used in staircase wiring to either on or off the light. It is of 6A.

**ONE-WAY SWITCH:** it is a device used to switch on lights of 6A.

**7/20 SWG (POWER WIRE):** they are used in power purposes for duty electrical appliances. 7/20 means 7 numbers of wires in the cable and 20 strands for thickness or gauge size.



**3/20 SWG (PHASE WIRING):** mostly used for house wiring purposes.

**3/22 SWG (NEUTRAL WIRE):** it is also used for house wiring purposes.

**1/18 SWG:** it is used for earthing.

**FLEXIBLE CABLE:** This is a temporary wire used for both power and light but temporarily. It is used as extension wire.

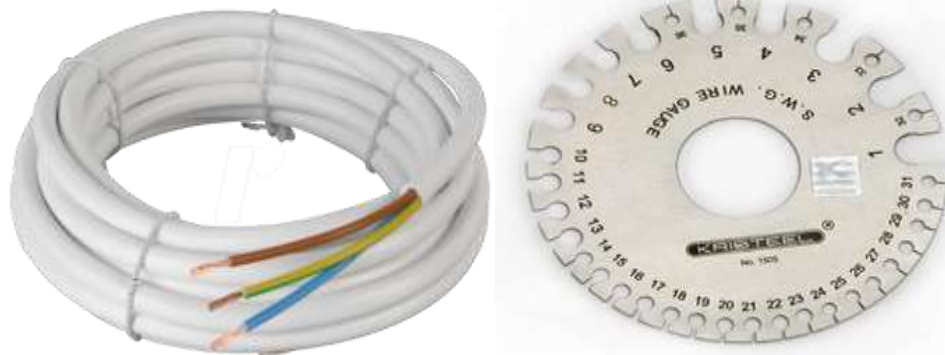

**SWG Round Wire Gauge:** It is used to measure the gauge of the wire.

## Experiments

### 1. Control a Light Bulb by a Single Way or One-way Switch

**Aim:** To study control a light bulb by a single way or one-way Switch

In this experiment, we will wire a light switch to control a light point by one way or single way switch.

We will use the basic SPST (Single Pole Single Through) switch in this experiment to control a lamp / bulb from single location.

Below is a simple step by step procedure with schematic and wiring diagram which shows how to wire a light, switch to control the bulb/lamp from single place with the help of one way or single way switch.

#### **Requirements**

- Single Way Switch (SPST = Single Pole Single Through) x 1 No
- Lamp (Light Bulb) x 1 No
- Short pieces of cables x 3 No

#### **Procedure:**

This is just like a series circuit i.e. all the components are connected in series. Just connect the Neutral wire directly to the light bulb and then connect the light bulb to the switch through middle wire. And then connect the live wire to the switch as shown in fig below. Fig given below shows the basic connection of light switch and their position i.e. when the switch is OFF, the circuit acts like an open circuit and the bulb won't glow. To switch on the bulb, switch  $S_1$  must be closed to complete the circuit and glow the light bulb.

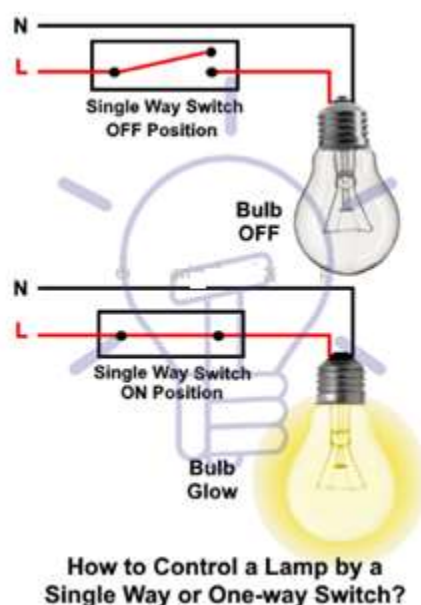

In figure below, schematic and wiring diagrams of light switches are shown which shows how to wire a light switch?



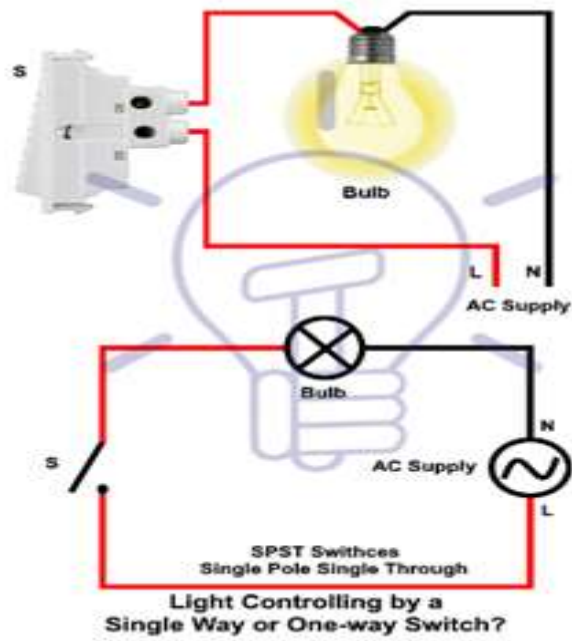

**Result:**

Thus the control of light bulb by a single way or one-way switch is prepared and tested for its operation.

## 2. Switch board containing at least two switches, one fan regulator and one 5A plug point

**Aim:** To prepare switch board containing at least two switches, one fan regulator and one 5A plug point

### **Material Required:**

S.No.	Material Description	Quantity
1.	5A one way switches	2
2.	5A 3-pin socket	1
3.	Fan regulator	1
4.	6" X 4" switch board	1
5.	1.5 mm <sup>2</sup> PVC insulated copper wire	Required

### **Procedure:**

1. Connections are given as per the circuit diagram.
2. Connect the Switch Board to Single phase 230V supply.
3. Test the Switch Board by using test lamp.



**Figure: Switch Board**

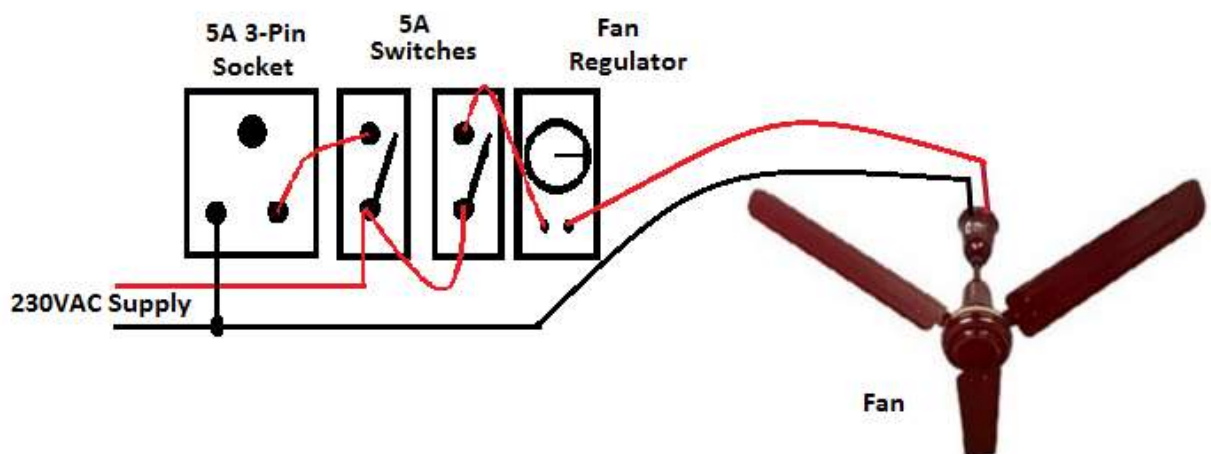

**Figure: Connection diagram of Switch Board**

### **Result:**

Thus the switch board prepared and tested for its operation.

### 3. Staircase wiring and Godown Wiring

**Aim:** To study staircase wiring and godown wiring

**Material Required:**

S.No.	Material Description	Quantity
1.	6A one way switches	4
2.	6A two way switches	2
3.	230V, 25W bulbs	3
4.	Batten holders	3
5.	1.5 mm <sup>2</sup> PVC insulated copper wire	---

**Theory:**

**Staircase wiring circuit diagram & working**

Staircase wiring is a common multi-way switching or two-way light switching connection. Here one lamp is controlled by two switches from two different positions. That is to operate the load from separate positions such as above or below the staircase, from inside or outside of a room, or as a two-way bed switch, etc.

A Staircase wiring makes the feasibility for the user to turn ON and OFF the load from two switches placed apart from each other.

**Staircase wiring circuit arrangement**

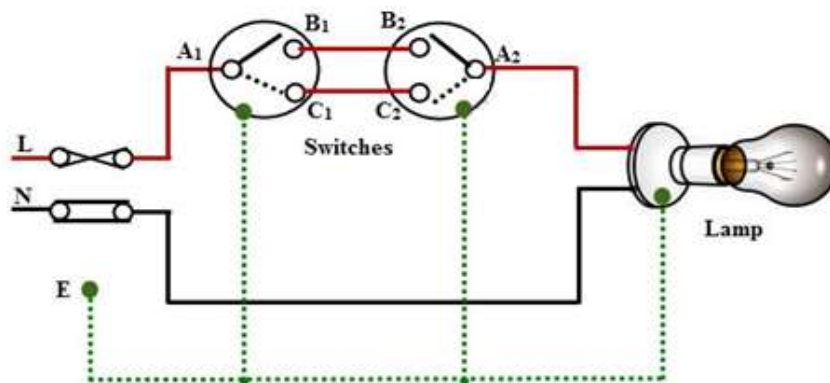

**Figure: 1**

The First pole and second pole of the SPDT switch S1 has connected to the corresponding first and second pole of the SPDT switch S2. That is similar poles of both two switches are connected each other.

The phase of the supply line is connected to the common pole of a switch. And the phase line to the load is taken from the common pole of the next switch. It makes an arrangement that, to close the circuit both the switches should be in the same position in order to make the two common poles in contact to achieve a closed circuit. Changing ON & OFF condition of a single switch can determine whether the circuit is closed or open.

Thus in staircase wiring, load can control from both positions. If a truth

table has made for the above system output, it will have a result similar to an XNOR gate. That is the light ON's when both the switches are in the same position.

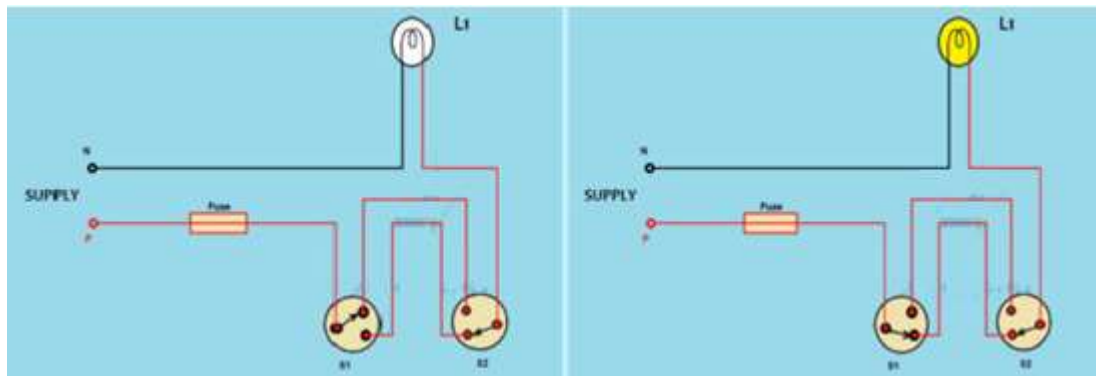

Figure: 2

Table: 1

Switch 1 Position	Switch 2 Position	Lamp Position
UP	UP	ON
UP	Down	OFF
Down	UP	OFF
Down	Down	ON

### Godown wiring circuit diagram and working

Godown wiring uses to operate lamps/loads in a sequential manner, where only one load operates at a time. As its name implies" Godown wiring ", it is commonly used for light switching in godowns, tunnel-like structures, long passages, etc., where the light is only required for passage or it requires only at one position at a time. The advantage of the godown wiring is the previous load will be turned off when we normally switch ON the next load.

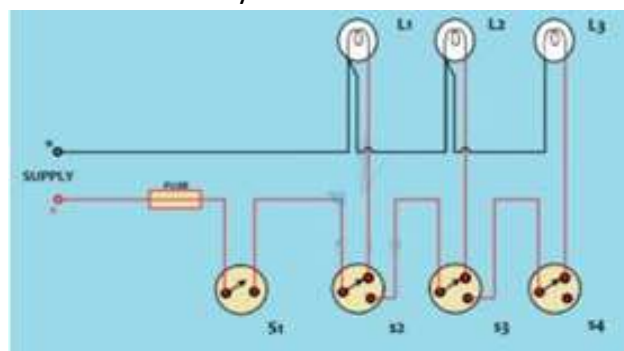

Figure: 3

In godown wiring, the loads are not controlled by a random switching. The user should follow a linear sequence in the switching, from one end to another. That is, to close the circuit for a final load the remaining switches should be ON. That is the load is in series with remaining switches from the beginning end. So the circuit opens if any of the previous switches have flipped OFF.

### Procedure

1. Make the connections as per the circuit diagram shown in Figure: 1.
2. Test the circuit as per the instruction given in Table: 1.

### Godown wiring circuit arrangement

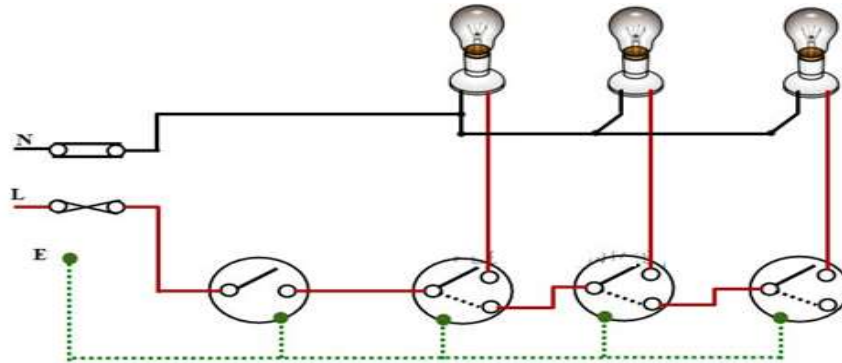

**Figure: 4**

The phase has connected to the common pole of the first switch. The 1st throw of the switch has connected to load. And the 2nd throw has connected to the common pole of the next switch. Initially, common poles of all the switches are positioned to the 1st throw of the SPDT switch. So in such an arrangement, changing the switch position to 2nd throw OFF's previous load and ON the next one. By this arrangement, an infinite number of loads can be connected in a sequence. Switch S1 in the circuit is SPST and remaining is SPDT also called as a changeover switch.

**Result:** Thus the Staircase wiring and Godown wiring are prepared and tested for its operation.

## 4. Fluorescent Tube Light

**Aim:** To study fluorescent tube light.

**Apparatus:** Tube, Tube Base, Starter, Choke and Wire.

**Construction:** Fluorescent tube is a low-pressure mercury vapour lamp. The lamp is in the form of long glass tube due to low pressure, with fluorescent powder coating to its inner surface.

Tungsten filaments coated with barium oxide are placed at each side of the tube. The tube contains small amount of mercury with small quantity of argon gas at low pressure. When the temperature increases, mercury changes into vapour form. At each end of the tube, electrode in spiral form is made of tungsten coated with electrons emitting barium. A capacitor is connected across the circuit to improve the power factor.

**Circuit Diagram:**

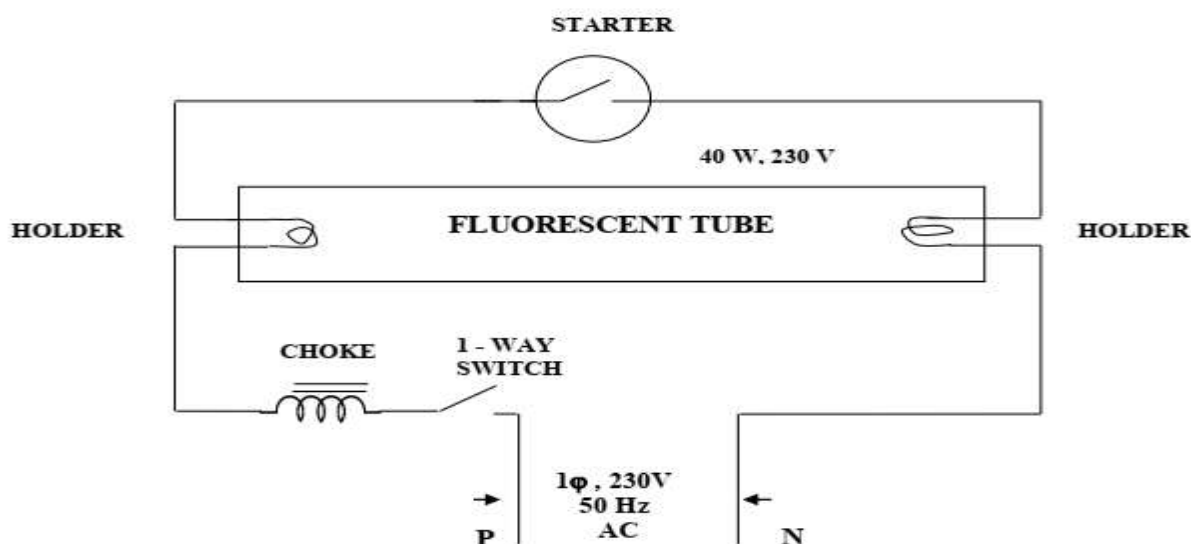

### **Procedure:**

1. Fix the tube holder and the choke on the tube base.
2. Phase wire is connected in the choke and neutral direct to the tube.
3. Fix the fluorescent tube between the holders.
4. Finally connect the starter in series with the tube.

### **Precautions:**

1. Tools should be used carefully.
2. Fitting should be tightly fitted.
3. Connection should be tight.
4. Wire should be on the conduit, power gripped properly

### **Result:**

Thus the fluorescent tube light wiring is prepared and tested for its operation.

**QUIZ:**

Q1.	What is the standard dia. of the tube light?	25 mm
Q2.	Which material is used for coating the tube?	Argon gas or neon
Q3.	Which gas is used in tube light?	Zinc silicate cadmium silicate
Q4.	What are the standard lengths of tube light?	6m, 1.2m and 1.5m
Q5.	What is the function of starter?	Yes, by shorting the two wires temporarily
Q6.	Why we use choke in tube light?	To supply high voltage during starting
Q7.	Name any two types of the starter?	Glow type, thermal type
Q8.	How much power consumed by the tube light?	40 watt approximately
Q9.	At which supply the tube is operated?	230 volt ac
Q10.	Can we start the tube light without a starter?	To complete the circuit initially

**Write the observations and experiences**



**House wiring 2**

- 1) Residential House Wiring Using fuse, switch, indicator, lamp and energy meter
- 2) Ceiling fan connection with regulator, switch and capacitor
- 3) Inverter connection diagram. Install inverter and battery at home

**Experiments**

**1. Residential house wiring using fuse, switch, indicator, lamp and energy meter**

**Aim:** To prepare residential wiring using fuse, switch, indicator, lamp and energy meter.

**Apparatus Required:**

S.NO.	Components Required	Range	Quantity
1.	One way Switch	----	1
2.	Energy Meter	1 Ph	--
3.	Indicator	-----	1
4.	Lamp	----	1
5.	Wires	----	Required amount

**Procedure:**

1. Connections are given as per the circuit diagram.
2. When the Switch is closed, the Lamp will glow and the metering is running.
3. The corresponding readings are noted from energy meter by observing number of cycles of the disc for a particular time period.

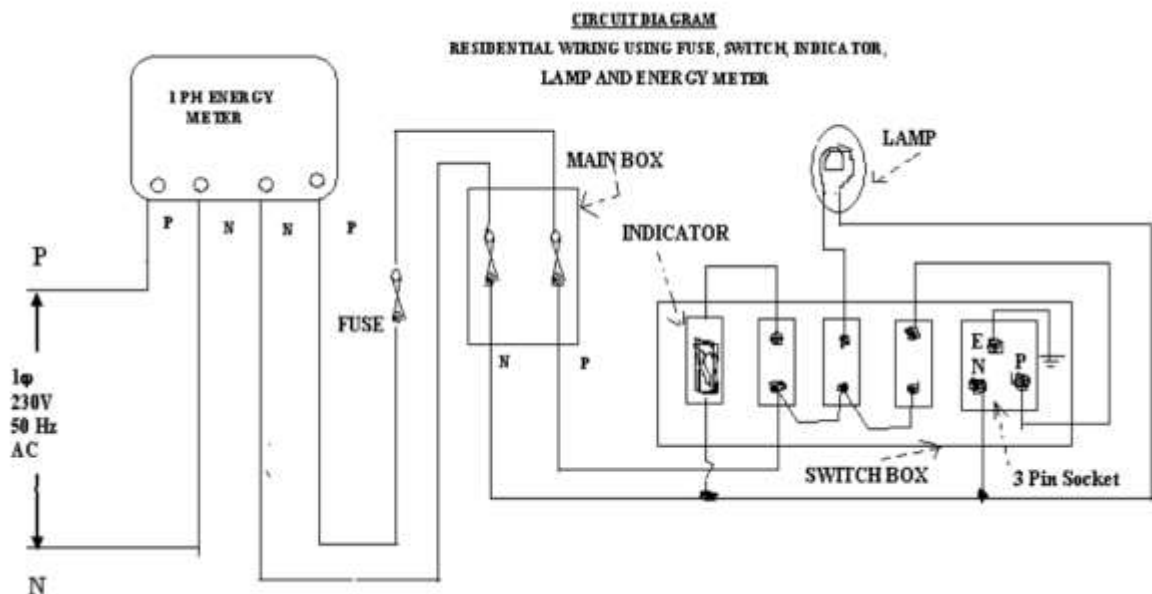

**Result:**

Thus the residential wiring using fuse, switch, indicator, lamp and energy meter wiring is prepared and tested for its operation.

## 2. Ceiling fan connection with regulator, switch and capacitor

**Aim:** To study the ceiling fan connection

**Material Required:**

S.No.	Material Description	Quantity
1.	Ceiling fan	1
2.	6A one way Switch	1
3.	Fan regulator	1
4.	1.5 mm <sup>2</sup> PVC insulated copper wire	---

**Theory:**

There are two windings in the ceiling fan, one is running winding and another is starting winding. We must connect the capacitor in series with the starting winding and then it connected across the power supply. On the other hand, the running winding is to be connected directly across the power supply.

So first of all, we need to identify the starting winding and running winding. Here the figure is given to better understand.

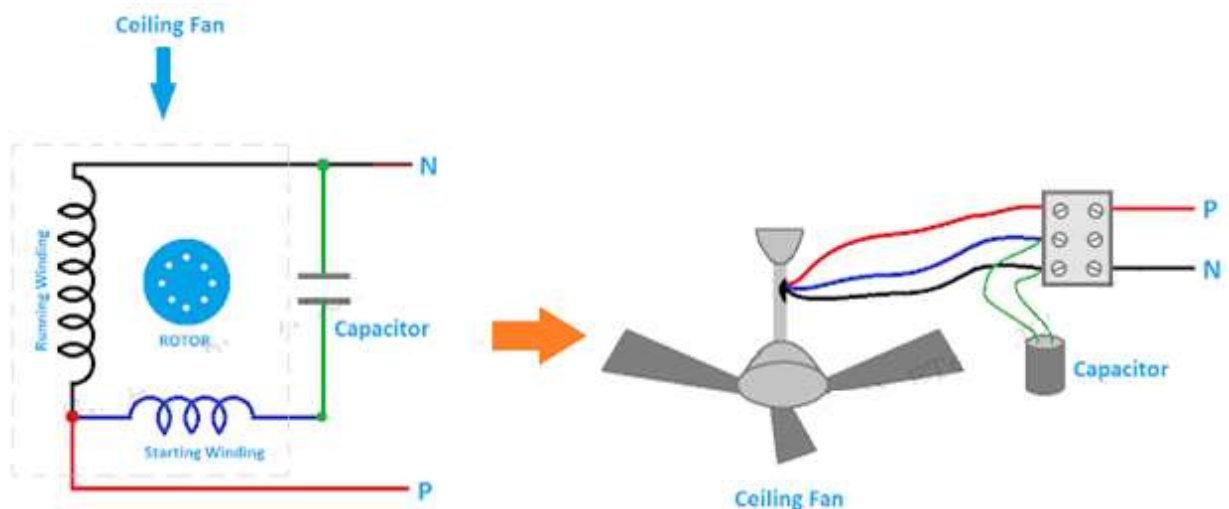

Capacitor Connection with Ceiling Fan

**Figure: Capacitor connected ceiling fan**

As seen in the above the ceiling fan has three terminals wire outside, red, black and blue. Generally, most of the ceiling fan has three wires outside. You can also see in the winding connection of ceiling fan, one terminal of each winding are connected together and it brought outside as a common wire.

We can identify the winding terminals by measuring resistance. You can identify the terminals of any ceiling which has different colors using this method.

Suppose in this case we have measured the resistance between,

1. Red and Black wire: 210 ohm
2. Red and Blue: 220 ohm

3. Blue and Black: 500 ohm

So as the resistance between blue and black is the highest so these are the terminals of running and starting winding. So the rest red terminal is common which is connected with both windings.

We know that the resistance of starting winding is greater than running winding. So as the resistance between Red and blue is greater than red and black, it is sure that blue is the terminal of starting winding and black is the running winding terminal.

Now, once you identified the terminals of the ceiling connect the capacitor between running and starting winding as shown in the above diagram.

### **Ceiling Fan connection**

Here you can see the connection of ceiling fan with regulator and switch. Connect first the switch in series, then connect the regulator and then connect the ceiling fan.

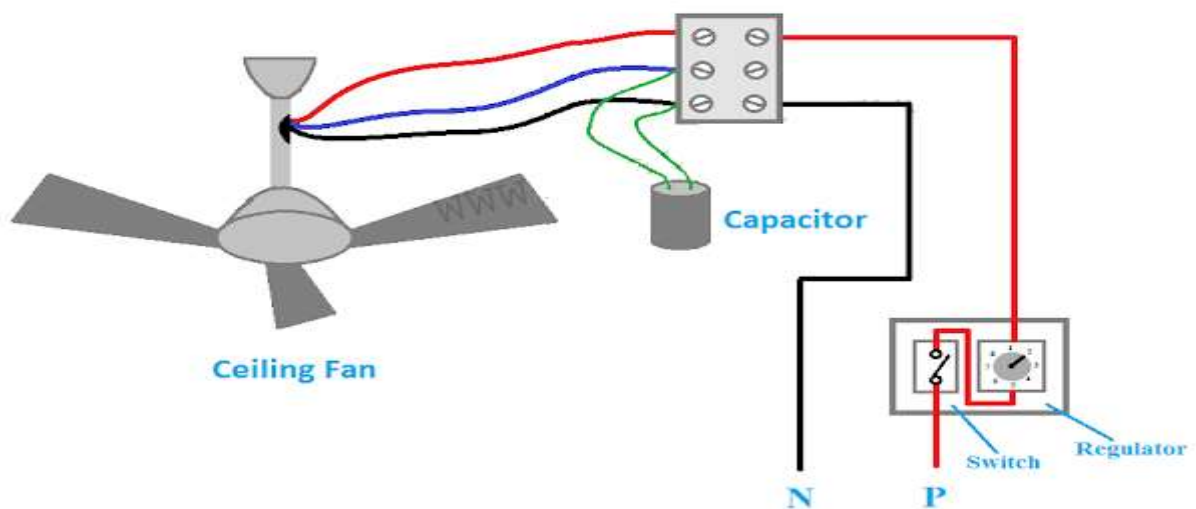

**Ceiling Fan Connection**

**Figure: 2**

### **Procedure:**

1. Make the connections as per the circuit diagram shown in Figure: 2.
2. Test the circuit and write down the observations.

### **Result:**

Thus the ceiling fan connection with regulator, switch and capacitor wiring is prepared and tested for its operation.

### **3. Inverter connection diagram-Installation of Inverter and battery at home**

**Aim:** To study circuit and working of home inverter

**Material Required:**

S.No.	Material Description	Quantity
1.	Single Phase Inverter	1
2.	12V-Lead Acid Battery	1
3.	Single Phase Energy Meter	1
4.	Switch Board (6-Switches + 1-3Pin Socket)	1
5.	Switch Board (1-Switches + 1-3Pin Socket)	1
6.	16A MCB	1
7.	1.5 mm <sup>2</sup> PVC insulated copper wire & 10 mm <sup>2</sup> PVC insulated copper wire with Lugs	---

**Theory:**

**Why we need Inverter?**

There is only one thing that is Battery is available by which we can store electrical energy for use during load shedding. But we know that battery is a DC source. In our home, all electrical equipment made for 230V AC supply. So we need 230V AC supply to run our electrical equipment during load shedding. The inverter in our house is a device which takes 12V DC supply and gives 230V AC Supply. So Inverter is a circuit or you can call a device which converts DC to AC.

**How to Select Rating of Inverter for Home?**

If you want to install an Inverter in your home then first you must select an Inverter of perfect rating which can drive the loads which you want. So the selection of rating of Inverter is very important.

For select the rating of the Inverter you need to calculate the load which you are want to run during load shedding.

For Example, you want to connect

2 Fan of 70 Watt = 140W

2 Tube Light of 60W= 120W

2 LED light of 15W = 30W

1 Television of 120W = 120W

3 CFL of 25W = 75W

So, the total load is = 485W

You need to select the rating more than your total load because when we just ON any electrical device it draws a much current at starting time. The inverter has the rating in KVA so you need to purchase 800KVA Inverter if your load is 500 W to 600W.

### How to select the rating of Battery for the inverter?

You must select the rating according to your required time of use that means if you want to use the inverter 3 hours and your load is 485W then the rating of the battery must be,

$$(485 \times 3) / 12 = 122 \text{Ah}$$

as 122Ah battery is not available in the market you can purchase 150Ah battery. The formula is **ampere-hour = (total load \* required time in hour)/battery voltage**

### Inverter connection diagram

The circuit diagram for an inverter connection at home is given below. According to the below circuit diagram you can see that during load shedding Light 3, fan and T.V can be run by the inverter. According to your requirement connect the load to the inverter. As the Neutral is common for all loads you did not need the neutral connection from the inverter individually.

### Circuit diagram of inverter connection at home:

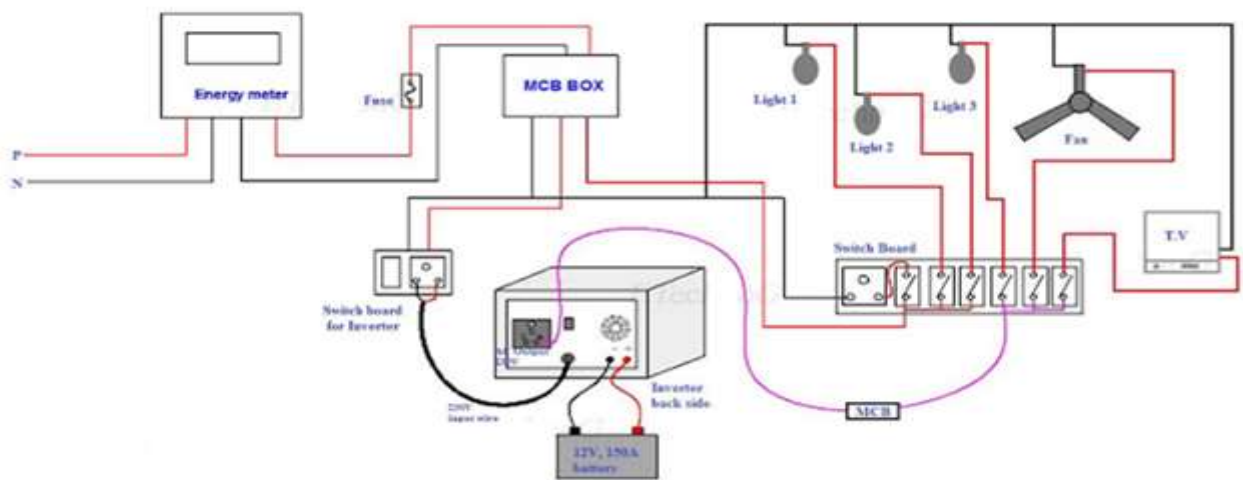

**Inverter Wiring Diagram for Home**

**Figure: 2**

### Procedure:

1. Make the connections as per the circuit diagram shown in Figure: 2.
2. Test the circuit and write down the observations.

### Result:

Thus the Inverter connection is prepared and tested for its operation.

**Write the observations and experiences**



**Electrical Safety:**

Electrical safety rules

Electrical Shock –causes for electric shock

Preventive measures to electric shock

Earthing

**Experiments:**

- 1) Demonstration of CPR
- 2) Earthing demonstration and field visit
- 3) Measurement of earth resistance

**Introduction to Electrical Safety**

Electricity is a useful and powerful tool in our daily life. Everything around us works with electricity such as lamps, TVs, computers, mobile phones and DVD players. Today, electricity has become such an essential part of our life that it is difficult to imagine life without it. Figure 1 shows examples of equipment that work on electricity, which demonstrate the importance of electricity in our daily life.



**Figure 1: Importance of electricity in our daily lives**

However, electricity is very dangerous. It can cause shock, burn or kill you. Electricity can also damage sensitive devices. Figure 2 gives examples of the dangers of electricity. This module covers the basic safety rules and practices that apply at home, outdoor, labs and workshops.



Figure 2 Dangers of electricity

### Home Safety

To protect your home from electrical risks and hazards, you need to follow some home safety tips that are illustrated below:



**DON'T** overload plugs as this can cause electrical fire.



**Never** use an electrical appliance in a wet area. This can cause an electric shock.



**DON'T** pull on the cable to remove a plug from the socket. This can damage the insulation and cause an electric shock or an electrical fire.



**Never** allow children to play with outlets. Inserting conductors in an electrical outlet is dangerous and can cause shock, which can kill a person.

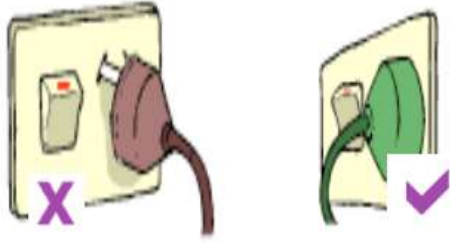

Plugs **should be** pushed carefully all the way into the power points.



**Replace** the socket outlet if the plug is loose in the socket or if it shows signs of damage.



**DON'T** make joints in a cable; replace it with one of adequate length.

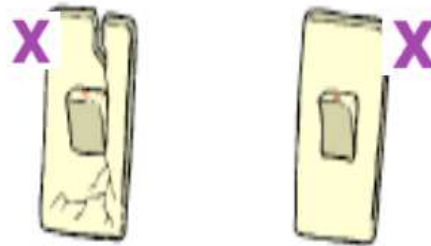

Switches and power points **should not** be cracked, broken or loose.

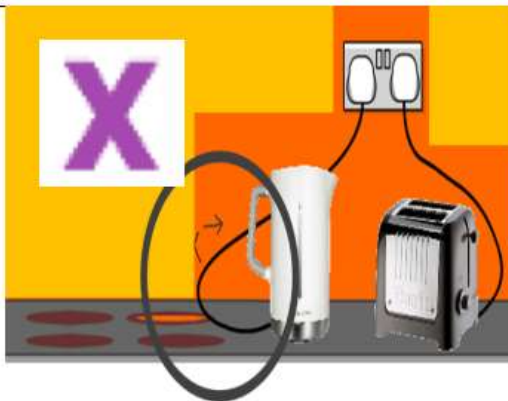

**DON'T** let leads from electrical equipment, such as toasters or kettles, trail across your cooker tops.



Always use plug protectors to stop small children from pushing things such as keys and pins into the power outlet.

### Outdoor Safety

There are many outdoor electricity sources that can cause electricity hazards such as high voltage power lines, electricity substations and transformer boxes. To avoid accidents and protect yourself from electrical injuries, follow the next tips:



### WHILE WORKING



**Never** bring ladders, long-handled tools or other items within 10 feet of an overhead power line.



**Never** touch the underground power lines.

### While Playing



**Never** play with transformers because they carry high voltages that can be deadly.



**Never** fly kites or model airplanes near electric power lines.

### WHILE PLAYING - cont.



**DON'T** play near live power lines. If you see a downed power line, stay as far away as possible and keep others away.



**DON'T** play near electricity substations. They contain powerful electrical equipment that is dangerous.



**DON'T** climb trees that are near power lines. This can seriously injure you.

Before you can use equipment and machines or attempt practical work in a workshop or a lab, you must understand basic safety rules. These rules will help keeping you and others safe in the workshop. Following safety rules will also prevent you and others from accidents, injuries as well as death. To avoid accidents and injuries in the workshops and labs, follow the next safety rules and practices:

**Before conducting workshop tasks, be familiar with the location of:**



Fire extinguishers



Fire alarm pull stations



First aid kits



Emergency telephone numbers.



Emergency exits.



Emergency stop button.



Smoking, eating or drinking are **not permitted** in labs and workshops



Keep the workshop clean and tidy at all times



Keep the workshop floor dry



Keep your tools and work area organized



Report accidents such as spills, burns, cuts or injuries to the teacher immediately



Wear safety shoes while working in a workshop. Sandals or slippers **are not allowed** in workshops



Keep your lab bench organized and free of bags and books



Don't joke or play with your friends inside the lab



Listen Carefully to all instructions and lab procedures from your teacher. Ask questions if you aren't sure.



Always use the appropriate personal protective devices and check that they are clean and in good condition.

### Safety and Accident Prevention Signs

We have seen a number of safety signs that read, "Warning", "Caution", or "Danger". Figure 3 show some common safety and accident prevention signs and their meanings.



 <b>Respiratory Protection</b>	 <b>Eye Protection</b>	 <b>Footwear protection</b>	 <b>Hearing Protection</b>
 <b>No Smoking</b>	 <b>Hand Protection</b>	 <b>Hard Hat Protection</b>	 <b>Highly Flammable</b>
 <b>High Voltage Hazard</b>	 <b>Biological Hazard</b>	 <b>No Walking</b>	 <b>Poisonous Hazard</b>

Figure 3: common safety and accident prevention signs

### Electric Shock

- An electrical shock is received when electrical current passes through the body.
- You will get an electrical shock if part of your body completes an electrical circuit by:
  1. Touching a live wire and the electrical ground as shown in **Figure 4**.
  2. Touching a live wire and another wire at a different voltage.



Figure 4: how can you get an electric shock?

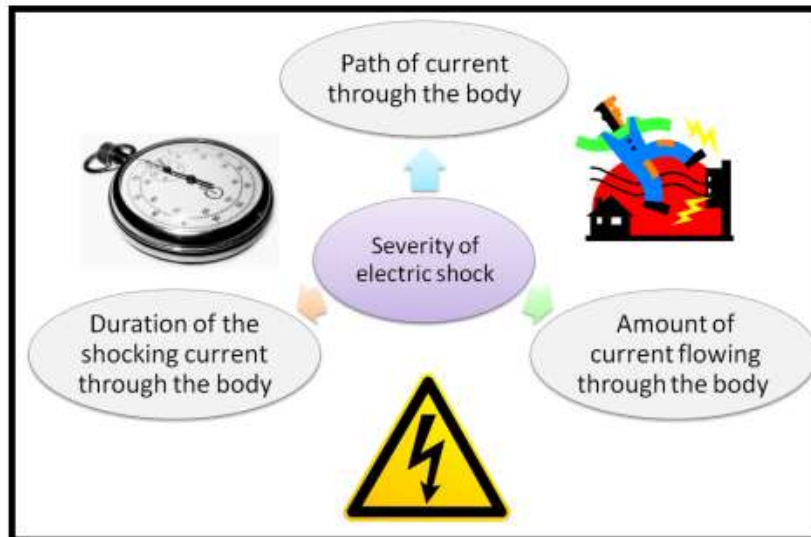

Figure 5: factors that determine the severity of electric shock

### Electric Shock – Current Levels

Current level (Milli amperes)	Probable Effect on Human Body
1 mA	Perception level. Slight tingling sensation. Still dangerous under certain conditions.
5 mA	Slight shock felt; not painful but disturbing. Average individual can let go. However, strong involuntary reactions to shocks in this range may lead to injuries.
6 - 16 mA	Painful shock, begin to lose muscular control. Commonly referred to as the freezing current or "let-go" range.
17 – 99 mA	Extreme pain, respiratory arrest, severe muscular contractions. Individual cannot let go. Death is possible.
100 – 2000 mA	Ventricular fibrillation (uneven, uncoordinated pumping of the heart.) Muscular contraction and nerve damage begins to occur. Death is likely



## Body resistance and heat effects of electric current

Body resistance (measured in ohms/cm<sup>2</sup>) is concentrated primarily in the skin and varies directly with the skin's condition.

- The resistance of **dry** well-keratinized intact skin is **20-30 kΩ /cm<sup>2</sup>**.
- The resistance of **moist** thin skin is about **0.5 kΩ/cm<sup>2</sup>**.
- The resistance of **punctured** skin may be as low as **0.2-0.3 kΩ/cm<sup>2</sup>**.
- The same resistance is in case of current applied to moist mucous membranes (e.g., mouth, rectum, and vagina).

If **skin resistance is low**, few, if any, burns occur, although **cardiac arrest** may occur if the current reaches the heart.

If **skin resistance is high**, much energy may be dissipated at the surface as current passes through the skin, and large surface burns can result at the **entry and exit points**.

Internal tissues are burned depending on their resistance; **nerves, blood vessels, and muscles** conduct electricity more readily than denser tissues (e.g., fat, tendon, bone) and are preferentially damaged.

The higher the resistance is the higher production of the heat is (heat = amperage<sup>2</sup> × resistance  $\diamond Q = I^2 \cdot R \cdot t$ ). If there is an element with high resistance in the circuit, it is usually hot, depending on the value of electric current (amperage) in the circuit and the resistance of the element.

## How to act in emergency situations

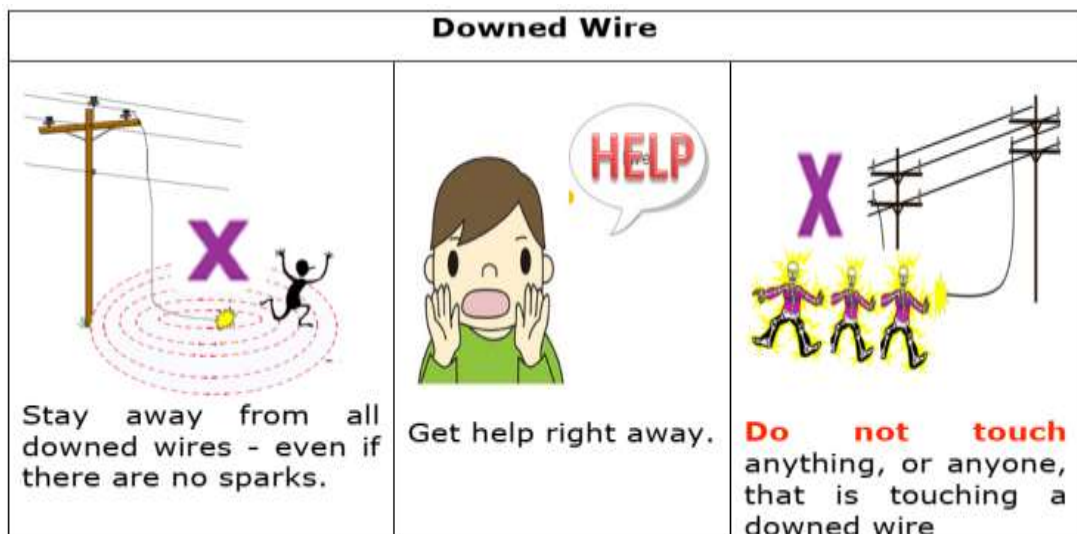

### Downed Wire Touching a Vehicle



If you are inside a vehicle, wait inside for help.



If you must get out, jump without touching the ground and the vehicle at the same time.

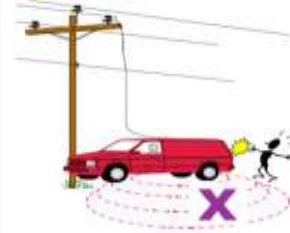

If you are a witness, stay clear and call for help.

### Electrical Fire



Get help right away.



Unplug the faulty appliance to turn off the power, **if possible.**

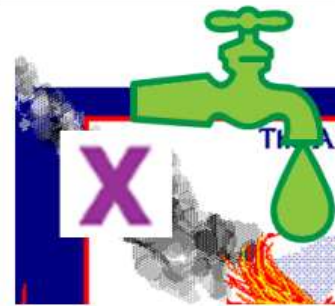

**Never** throw water on an electrical fire

### Electrical Shock



**Never** touch a person who is being shocked.





Unplug the faulty appliance or turn off the power, **if possible.**





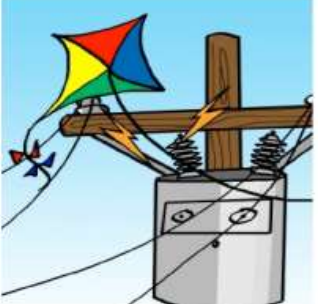

Call for help immediately

**Class & Lab Activities**

**Activity 1:** Indicate the safe and unsafe behavior in the following pictures. Give Reasons

Behavior	Safe	Not safe
		
		
		
		

**Activity 2:** Sort the following items into conductors and insulators

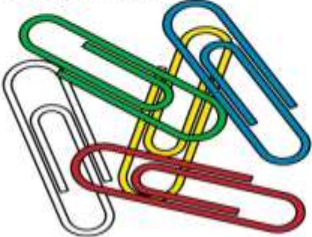
	<b>Conductor</b>	<b>Insulator</b>
<b>Metallic key</b> 		
<b>Cartoon box</b> 		
<b>Plastic ruler</b> 		
<b>Water</b> 		
<b>Paper clips</b> 		

**Activity 3:** Fill in the following table

<b>Term</b>	<b>Symbol</b>	<b>Unit</b>	<b>Measuring Device</b>
<b>Resistance</b>	<b>R</b>		
<b>Voltage</b>		<b>volts (V)</b>	
<b>Current</b>			<b>Ammeter</b>

**Activity 4:** Complete following sentences

• The severity of the electric shock depends on:

1. \_\_\_\_\_
2. \_\_\_\_\_
3. \_\_\_\_\_

- List three tips for workshop and lab safety:

1. \_\_\_\_\_
2. \_\_\_\_\_
3. \_\_\_\_\_











- What should you do if you see a downed wire?

1. \_\_\_\_\_
2. \_\_\_\_\_
3. \_\_\_\_\_

**Activity 5:** Identify and name the following safety equipment

		
<p>_____</p>	<p>_____</p>	<p>_____</p>

**Activity 6:** Write the name of each of signs shown below

			
<p>_____</p>	<p>_____</p>	<p>_____</p>	<p>_____</p>
			
<p>_____</p>	<p>_____</p>	<p>_____</p>	<p>_____</p>
			
<p>_____</p>	<p>_____</p>	<p>_____</p>	<p>_____</p>

**Activity 7:** Differentiate between the circuits shown in the figures below by answering the following questions:

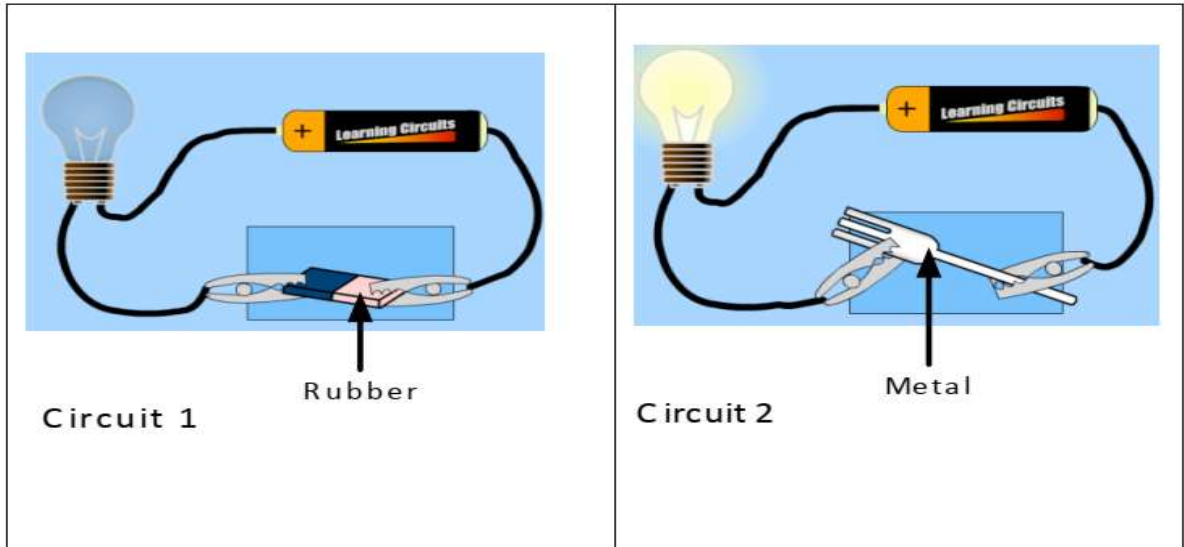

a) The lamp in circuit 1 is off. Give reason

---

---

b) The lamp in circuit 2 is on. Give reason

---

---

### **Earthing**

**Definition:** The process of transferring the immediate discharge of the electrical energy directly to the earth by the help of the low resistance wire is known as the electrical earthing. The electrical earthing is done by connecting the non-current carrying part of the equipment or neutral of supply system to the ground.

Mostly, the galvanised iron is used for the earthing. The earthing provides the simple path to the leakage current. The short circuit current of the equipment passes to the earth which has zero potential. Thus, protects the system and equipment from damage.

### **Types of Electrical Earthing**

The electrical equipment mainly consists of two non-current carrying parts. These parts are neutral of the system or frame of the electrical equipment. From the earthing of

these two non-current carrying parts of the electrical system earthing can be classified into two types.

(i) Neutral Earthing

(ii) Equipment Earthing.

### **(i) Neutral Earthing**

In neutral earthing, the neutral of the system is directly connected to earth by the help of the GI wire. The neutral earthing is also called the system earthing. Such type of earthing is mostly provided to the system which has star winding. For example, the neutral earthing is provided in the generator, transformer, motor etc.

### **(ii) Equipment Earthing**

Such type of earthing is provided to the electrical equipment. The non-current carrying part of the equipment like their metallic frame is connected to the earth by the help of the conducting wire. If any fault occurs in the apparatus, the short-circuit current to pass the earth by the help of wire. Thus, protect the system from damage.

### **Importance of Earthing**

The earthing is essential because of the following reasons

- The earthing protects the personnel from the short circuit current.
- The earthing provides the easiest path to the flow of short circuit current even after the failure of the insulation.
- The earthing protects the apparatus and personnel from the high voltage surges and lightning discharge.

Earthing can be done by electrically connecting the respective parts in the installation to some system of electrical conductors or electrodes placed near the soil or below the ground level. The earthing mat or electrode under the ground level have flat iron riser through which all the non-current-carrying metallic parts of the equipment are connected.



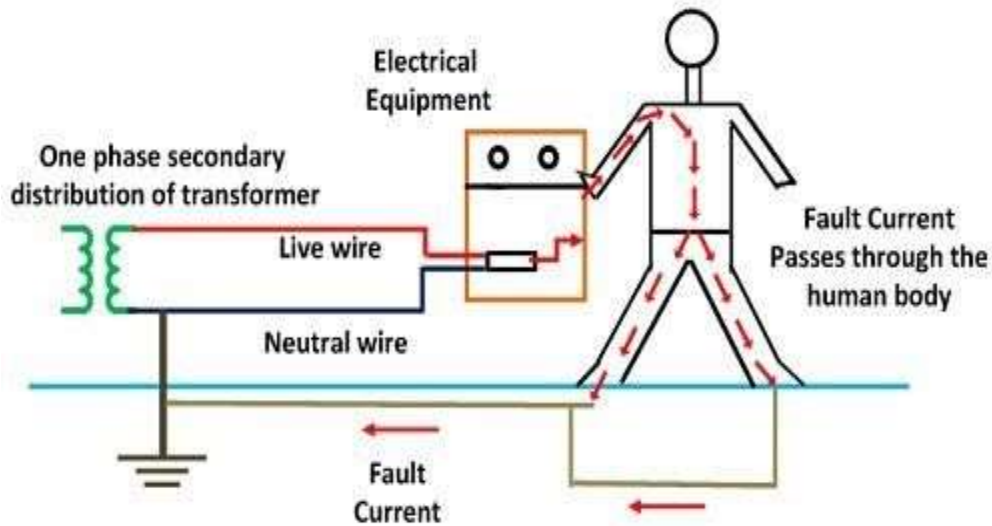

**Electrical System Without Earthing**

Circuit Globe

When the fault occurs the fault current from the equipment flows through the earthing system to the earth and thereby protect the equipment from the fault current. At the time of the fault, the earth mat conductors rise to the voltage which is equal to the resistance of the earth mat multiplied by a ground fault.

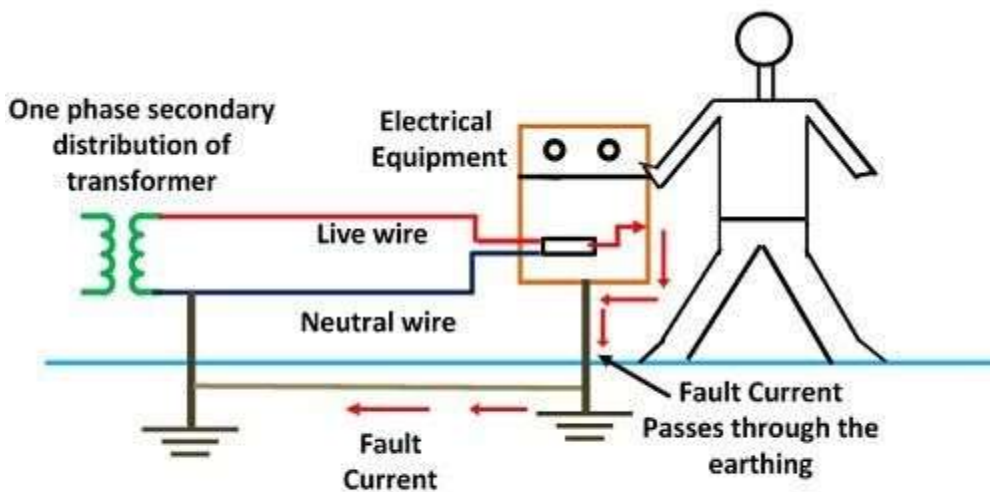

**Electrical System With Earthing**

Circuit Globe

The contacting assembly is called earthing. The metallic conductors connecting the parts of the installation with the earthing are called electrical connection. The earthing and the earthing connection together called the earthing system.



## Experiments

### 1. Demonstration of Cardio Pulmonary Resuscitation (CPR)

**Aim:** Demonstration of Cardio Pulmonary Resuscitation

**Explanation:** It is an emergency life-saving procedure that is done when someone's breathing or heartbeat has stopped. This may happen after a medical emergency, such as an electric shock and heart attack. CPR combines rescue breathing and chest compressions.

**CPR: Step by step procedure**



There are two main stages to CPR: the preparation stage and the CPR stage.

#### **Preparation steps**

Before performing CPR on an adult, use the following preparation steps:

##### **Step 1. Call 108**

First, check the scene for factors that could put you in danger, such as traffic, fire, or falling masonry. Next, check the person. Do they need help? Tap their shoulder and shout, "Are you OK?"

If they are not responding, call 108 or ask a bystander to call 108 before performing CPR. If possible, ask a bystander to go and search for an AED machine. People can find these in offices and many other public buildings.

## **Step 2. Place the person on their back and open their airway**

Place the person carefully on their back and kneel beside their chest. Tilt their head back slightly by lifting their chin.

Open their mouth and check for any obstruction, such as food or vomit. Remove any obstruction if it is loose. If it is not loose, trying to grasp it may push it farther into the airway.

## **Step 3. Check for breathing**

Place your ear next the person's mouth and listen for no more than 10 seconds. If you do not hear breathing, or you only hear occasional gasps, begin CPR.

If someone is unconscious but still breathing, do not perform CPR. Instead, if they do not seem to have a spinal injury, place them in the recovery position. Keep monitoring their breathing and perform CPR if they stop breathing.

## **Step 4. Perform 30 chest compressions**

Place one of your hands on top of the other and clasp them together. With the heel of the hands and straight elbows, push hard and fast in the center of the chest, slightly below the nipples.

Push at least 2 inches deep. Compress their chest at a rate of at least 100 times per minute. Let the chest rise fully between compressions.

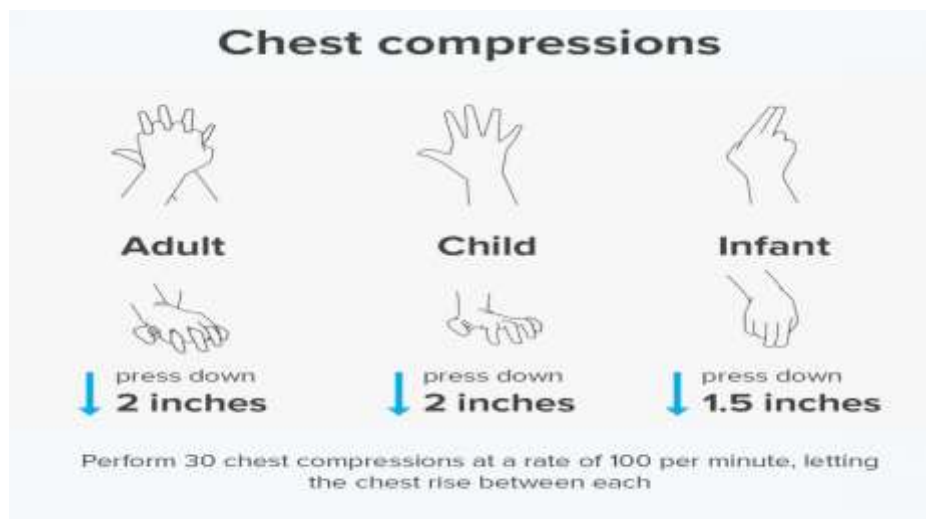

## **Step 5. Perform two rescue breaths**

Making sure their mouth is clear, tilt their head back slightly and lift their chin. Pinch their nose shut, place your mouth fully over theirs, and blow to make their chest rise.

If their chest does not rise with the first breath, retilt their head. If their chest still does not rise with a second breath, the person might be choking.

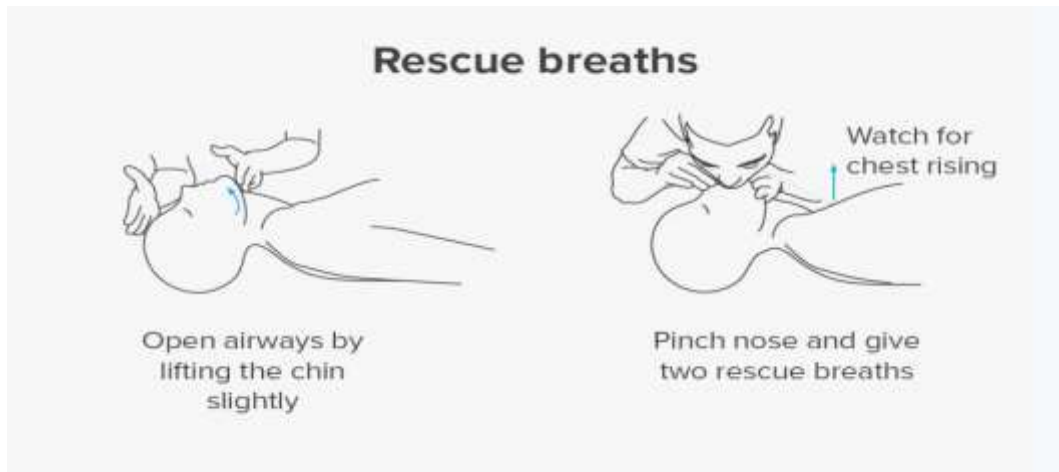

**Step 6. Repeat**

Repeat the cycle of 30 chest compressions and two rescue breaths until the person starts breathing or help arrives. If an AED arrives, carry on performing CPR until the machine is set up and ready to use.

**Result:**

The Cardio Pulmonary Resuscitation (CPR) is demonstrated.

## **2. Earthing demonstration and field visit**

**Aim:** Study the various types of earthing for electrical systems, Practice of earthing and measurement of earth resistance of campus premises.

**Apparatus:**

S. No.	Description	Qty
1.	Earth Tester	1
2.	Connecting wire	5m
3.	Measurement Tape	1

**Theory:**

The process of electrically connecting to the earth itself is often called "earthing". The main reason for doing earthing in electrical network is for the safety. When all metallic parts in electrical equipment are grounded then if the insulation inside the equipment fails there are no dangerous voltages present in the equipment case. If the live wire touches the grounded case then the circuit is effectively shorted and fuse will immediately blow. When the fuse is blown then the dangerous voltages are away.

The main reason for doing earthing in electrical network is for the safety. When all metallic parts in electrical equipment are grounded then if the insulation inside the equipment fails there are no dangerous voltages present in the equipment case. If the live wire touches the grounded case then the circuit is effectively shorted and fuse will immediately blow. When the fuse is blown then the dangerous voltages are away.

Connection to earth is achieved by embedding a metal plate or rod or conductor in earth. This metal plate or rod or conductor is called as "Earth electrode". Effectiveness of the earthing connection made by embedding a metal plate in earth is quantified as "Earth Resistance". This earth resistance is measured in ohms.

**Need of good earthing:**

1. To save human life from danger of electrical shock or death by blowing a fuse i.e. to provide an alternative path for the fault current to flow so that it will

not endanger the user.

2. To protect buildings, machinery & appliances under fault conditions i.e. to ensure that all exposed conductive parts do not reach a dangerous potential.
3. To provide safe path to dissipate lightning and short circuit currents.
4. To provide stable platform for operation of sensitive electronic equipment i.e. to maintain the voltage at any part of an electrical system at a known value so as to prevent over current or excessive voltage on the appliances or equipment.
5. To provide protection against static electricity from friction

#### **Main Objectives of earthing systems are:**

1. Provide an alternative path for the fault current to flow so that it will not endanger the user.
2. Ensure that all exposed conductive parts do not reach a dangerous potential.
3. Maintain the voltage at any part of an electrical system at a known value so as to prevent over current or excessive voltage on the appliances or equipment.

#### **Types of Earthing**

The earthing is broadly divided as

1. System or Neutral Earthing
2. Equipment Earthing

#### **System Earthing or Neutral Earthing**

This is primarily concerned with the protection of Electrical equipment by stabilizing the voltage with respect to ground (Connection between part of plant in an operating system like LV neutral of a Power Transformer winding and earth).

Ground or earth in a mains (AC power) electrical wiring system is a conductor that provides a low-impedance path back to the source to prevent hazardous voltages from appearing on equipment. Under normal conditions, a grounding conductor does not carry current.

**Neutral** is a circuit conductor that may carry current in normal operation, and is connected to ground (earth) at the main electrical panel.

In a poly-phase or three-wire (single-phase) AC system, the neutral conductor is intended to have similar voltages to each of the other circuit conductors.

#### **Equipment Earthing**

This is primarily concerned with the protection of personnel from electric shock by maintaining the potential of noncurrent carrying equipment at or near ground potential. Connecting frames of equipment (like motor body, Transformer

tank, Switch gearbox, operating rods of Air break switches, etc) to earth.

The system earthing and safety earthing are interconnected and therefore fault current flowing through system ground raises the potential of the safety ground and also causes steep potential gradient in and around the Substation. But separating the two earthing systems have disadvantages like higher short circuit current, low current flows through relays and long distance to be covered to separate the two earths .After weighing the merits and demerits in each case, the common practice of common and solid (direct) grounding system designed for effective earthing and safe potential gradients is being adopted.

### **Types of Earth Electrode**

1. Rod electrode
2. Pipe electrode

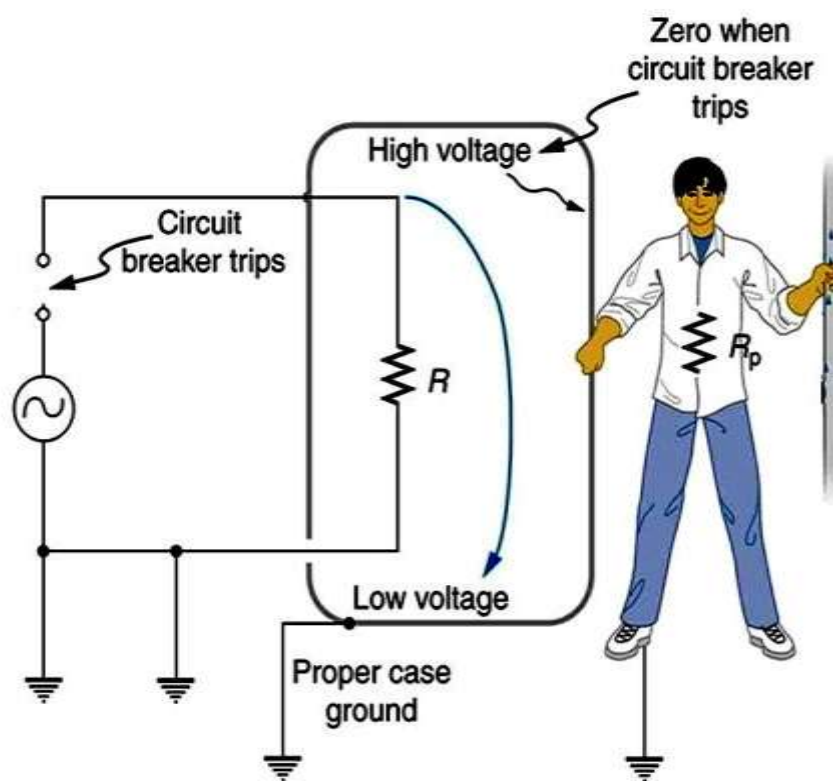

### **Plate Type Earthing**

In this, cast Iron plate of size 600mmX600mmX6.3mm thick plate is being used as earth plate. This is being connected with hot dip GI main earth strip of size 50mm X 6mm thick X 2.5 meter long by means of nut, bolts & washers of required size. The main earth strip is connected with hot dip GI strip of size 40mm X 3mm of required length as per the site location up to the equipment earth/neutral connection.

The earth plate is back filled & covered with earthing material (mixture of charcoal & salt) by 150mm from all six sides. The remaining pit is backfilled with excavated earth. Along with earth plate, rigid PVC pipe of 2.5 meter long is also provided in the earth pit for watering purpose for to keep the earthing resistance within specific limit.

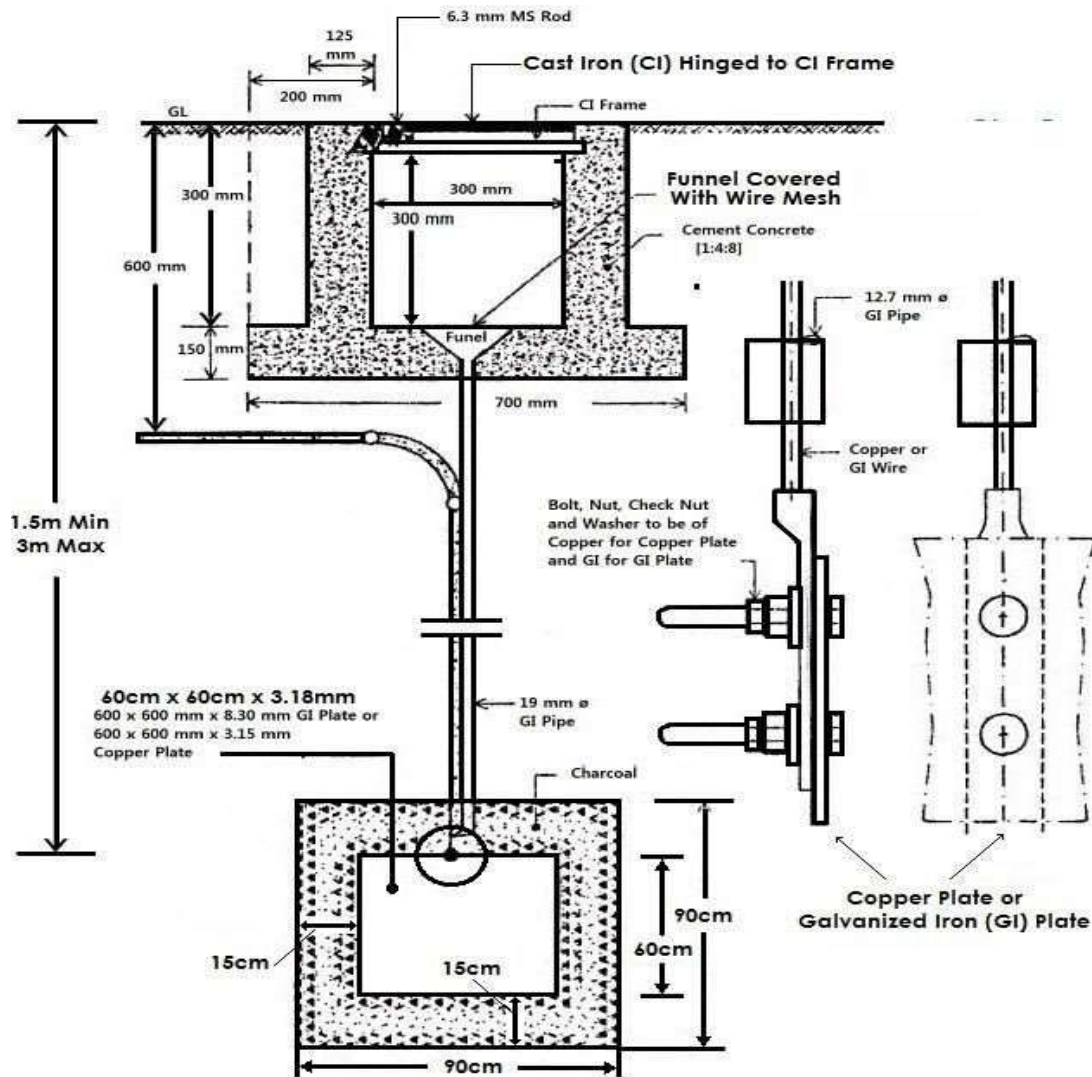

**Fig.: Plate Earthing**

### **Pipe Type Earthing**

In this hot dip GI pipe of size 40mm dia X 2.5 meter is being used for equipment earthing. This pipe is perforated at each interval of 100mm and is tapered at lower end. A clamp is welded with this pipe at 100mm below the top for making connection with hot dip GI strip of size 40mm X 3mm of required length as per the site location up to the equipment earth/ neutral connection. On its open end funnel is being fitted for watering purpose. The earth pipe is placed inside 2700mm depth pit.

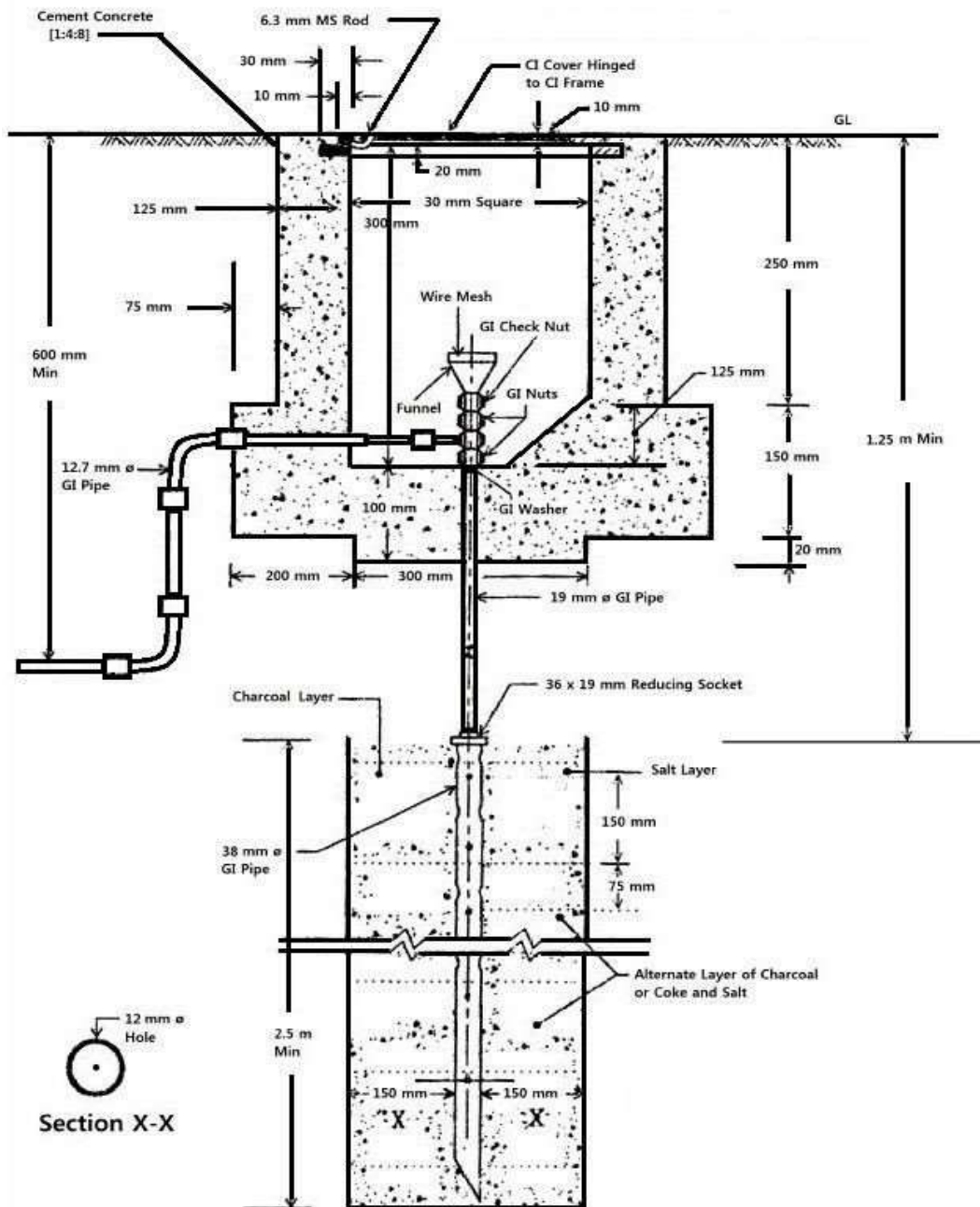

**Fig.: Pipe Earthing**

A 600mm dia of GI sheet in two halves is placed around the pipe. Then the angular space between this GI sheet and earth pipe is back filled with alternate layer of 300mm height with salt and charcoal. The remaining space outside of GI sheet will be backfilled by excavated earth. The GI sheet is gradually lifted up as the backfilling up progresses. Thus the pit is being filled up to the 300mm below the ground level. This remaining portion is covered by constructing a small chamber of bricks that top opened of pipe and connection with main earth pipe will be accessible for attending when necessary.



The chamber is closed by wooden/stone cover. Water is poured into the pipe through its opened funnel to keep the earthing resistance within specific limit.

**Other types of earthing:** When the capabilities of certain equipment are limited, they may not withstand certain fault currents then the following types of earthing are resorted to limit the fault current. (a) Resistance earthing (b) Reactance earthing (c) Peterson coil earthing.(d) Earthing through grounding transformer.

#### **Factors That Change the Requirement of Earth Electrode**

- If an electrical facility can expand in system, it creates different routes in the electrode. What was formerly a suitable low earth resistance can become obsolete standard.
- More number of metallic pipes, which were buried under ground, becomes less and less dependable as effective low resistance ground connection.
- Most of the location, the water table gradually falling. In a year or two, area ends up with dry earth of high resistance.
- These factors emphasize the importance of a continuous, periodic program of earth resistance testing

#### **Why Measure Soil Resistivity measurement is required?**

Soil resistivity measurements have a threefold purpose.

1. Such data are used to make sub-surface geophysical surveys as an identifying ore (a type of rock) locations, depth to bedrock and other geological phenomena.
2. Resistivity has a direct impact on the degree of corrosion in underground pipe lines. A decrease in resistivity relates to an increase in corrosion activity and therefore dictates the protective treatment to be used.
3. Soil resistivity directly affects the design of a grounding system, and it is to that task that this discussion is directed. When designing an extensive grounding system, it is advisable to locate the area of lowest soil resistivity in order to achieve the most economical grounding installation.

#### **Result:**

Various types of earthing for electrical systems, Practice of earthing and measurement of earth resistance of campus premises were completed.

#### **4. Measurement of earth resistance by use of earth tester by three point method or fall potential test**

**Aim:** Study the Measurement of earth resistance by use of earth tester by three point method or fall potential test

The fall of potential method is the most recognized method for measuring the resistance to earth of a grounding system, or the ground system performance. It is based on an IEEE standard, and when properly performed, is a very accurate test.

Take measurement in different directions as shown in below fig. If we rotate generator handle with specific speed we get directly earth resistance on scale. Spike length in the earth should not be more than 1/20 th distance between two spikes. Resistance must be verified by increasing or decreasing the distance between the tester electrode and the spikes by 5meter. Normally the X-Z distance should be proportion of 62% of D (Distance between earth electrode & current spike).

#### **Procedure:**

1. Connect C1 and P1 terminals on the test set to the earth electrode (Fig.).
2. Drive a probe into the earth 100 to 200 feet from the center of the electrode and connect to terminal C2. This probe should be driven to a depth of 6–12 inches.
3. Drive another probe into the earth midway between the electrodes and probe C2 and connect to terminal P2. This probe should be driven to a depth 6–12 inches.
4. Record the resistance measurement.
5. Move the potential probe 10feet far the away from the electrode and make a second measurement.
6. Move the potential probe 10feet closer to the electrode and make a third measurement.
7. If the three measurements agree with each other within a few percent of their average, then the average of the three measurements may be used as the electrode resistance.
8. If the three measurements disagree by more than a few percent from their average, then additional measurement procedures are required.

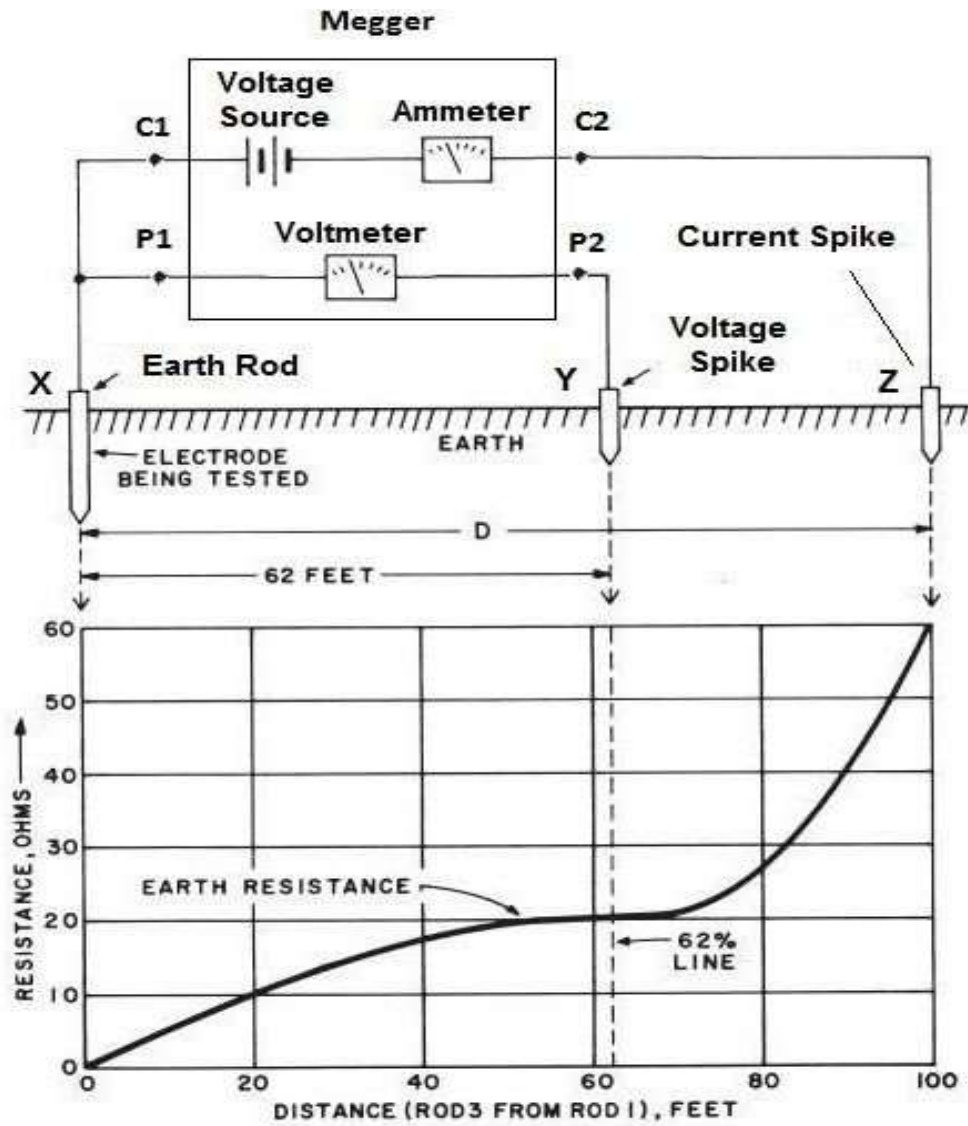

Fig.: Fall Potential Method

Observation Table:

S. No.	Voltage in Volt	Current in Amp	Resistance in ohms	Distance in meter

### **Treatments to for minimizing earth resistance**

- Remove Oxidation on joints and joints should be tightened.
- Poured sufficient water in earth electrode.
- Used bigger size of Earth Electrode.
- Electrodes should be connected in parallel.
- Earth pit of more depth & width-breadth should be made.

### **Result:**

Measurement of earth resistance by use of earth tester by three point method or fall potential test is completed.

**Household Electrical appliances:**

Dismantling and assembling of different electrical appliances (steam iron box, electric geyser, Table fan and Ceiling fan.

Experiments:

- 1) Dismantling and assembling of steam iron box
- 2) Dismantling and assembling of an electric geyser
- 3) Dismantling and assembling of Table fan
- 4) Dismantling and assembling of Ceiling fan

**Assembling and dismantling of steam iron box**

There are many manufacturers of irons, however, structurally, all models differ little. The shape, quality and quantity of spare parts, the heating rate of devices can be different, but they all have the same components. It:

- A container for steaming water.
- A housing made of heat-resistant plastic with a heat-insulating gasket.
- Sole in which the TEN is built in. This work surface has openings for steam to escape.
- Automatic steam dispenser.
- Water / steam nozzle.
- Thermostat that allows you to select the desired temperature for heating the sole of the device.
- Power cord for connecting to the network.

If there is nothing complicated in the device of this type of household appliances, then in the task called “how to disassemble the iron” there are a great many riddles and obstacles in the way of the master. We have to thank for this the manufacturers, who are extremely negative about the initiative of the owners.

**Types of electrical appliances**

This is the most common household appliances; therefore, its owners encounter breakdowns quite often. Irons come in three types.



- Ordinary, devoid of steaming function. Now they are not so popular, but their small cost and compactness allows the use of such devices as a “camping” option, saving clothes on trips.
- Partitions with a steamer — a water tank. There are small openings on the soles of these handy devices that allow steam to escape. These irons are, on the contrary, very much in demand.
- Irons with a steam generator — steam stations. These devices have a separate water tank, a heating element is built into it, and steam is supplied to the sole of the iron through a special steam line.



Devices with steamers are the golden mean, this explains their popularity. Repair of such devices is not too complicated, the main thing is to «get to the truth» — to find those responsible for the breakdown.

### **Types of problems and their causes**

Before disassembling the iron, it does not hurt to get acquainted with the list of more common malfunctions, and with their possible provocateurs.

1. The device does not want to turn on. In this case, the fault most often lies on the power cord damaged in one or several places.
2. The iron shuts itself off. This is proof of the correct operation of the thermostat of devices with an automatic shutdown function. The goal is protection against overheating.
3. The temperature controller is not working. There may be several reasons. Among them, carbon deposits formed on the contacts, damage to the bimetallic plate, damage to the rod-rod.
4. The appliance does not heat up. Blame TEN. Replacing this element is impractical in any case, since it is quite expensive.
5. Water flows out of the iron. The valve for supplying fluid to the sole is to blame, or rather, its damaged gum. Independent replacement will fail.
6. Poor steaming system. This trouble is a consequence of the use of low-quality water. Optimum distilled, refined or boiled.

7. Steam button does not work. The tube located inside has broken (cracked).



Having learned in advance which unit can be blamed for the problem, there is a chance to carry out repairs quickly and efficiently, but this operation is far from always successful.

### **What do you need to work?**

In order not to be distracted by the search for everything you need for work, you need to collect a whole set of different tools and materials near the iron in advance. For disassembly and repair, with a high degree of probability, you will need:

- electrical tape or heat shrink tubing;
- pencil (stylus);
- multimeter (tester);
- sandpaper (fine grain);
- scissors;
- screwdrivers — regular and Phillips;
- soldering iron;
- plastic (old) card or a wide knife (for opening latches);
- pliers (platypuses, ducks).



After collecting all the materials, you can begin to slowly and accurately disassemble the unit.

### **How to disassemble the iron?**

The small dimensions of the household appliance in this case are a big drawback, not a dignity: all the fasteners are “hidden” in those places where it is most difficult to get. Another difficulty is the fastener latches made of plastic, they are quite easy to damage, so maximum care and accuracy are required.

### **Instruments Bosch, Brown, Philips**



The dismantling order of these irons is the same, since the designs are very similar. Dismantling of mini-units is carried out according to a typical scheme.

1. Take a screwdriver and unscrew the two bolts «settled» on the back cover of the device. If the terminal box does not look the best (the cord is melted, the contact is blown), then the iron will not be further disassembled.
2. Remove (pry) the central cover, which goes to the regulator from the back wall. Armed with a flat screwdriver for this operation.
3. Remove the temperature control knob. At this stage, they act cautiously, because you can not lose the spring of the switch dial.
4. Take out the control unit and the heating element connector, then the indicator with the power cord. Here, to alternately bend the latches, a long screwdriver is used.
5. Pull out — pull back — the entire electrical part, then remove the spray cap. The screw located behind it is unscrewed with a Phillips screwdriver.
6. Remove the sole: disconnect the 2 latches located on the back of the iron.

*After identifying and fixing the breakdown, assembly work is carried out in the reverse order. Haste during work will inevitably lead to damage to the elements of the device, so they act slowly and patiently.*



## Irons Scarlet, Roventa



In this case, the algorithm of actions is slightly different, therefore, they act differently.

1. First remove the protective cap located on the back of the iron, which conceals the fastening screw. Do the work with a knife or scissors.
2. To unscrew the screw inside, use small platypus pliers or scissors, since the head of the fastener is non-standard — not one of the screwdrivers will fit it.
3. In order to maximally facilitate possible future work, in place of an uncomfortable screw, they select the fastener whose head is suitable for screwdrivers.
4. Remove the lid, which closes the opening of the water tank. They take a Phillips screwdriver, unscrew the screw hidden there.
5. Remove the upper part of the handle, then unscrew the remaining fasteners. Remove the temperature control knob with a knife.
6. Remove the upper part of the iron body, then use a Phillips screwdriver to unscrew the screws holding the sole of the appliance.

Having finished with the last stage, they begin to search for damage. The most important thing when disassembling the device is accuracy and smoothness of action. In no case can you pull the levers, knobs and buttons with all their might. If something rests somewhere, then first you need to explore all the possible obstacles, and then squeeze or unscrew them. Particularly reverent relationships require insidious latches, as these flimsy structures break “with pleasure” — elementary and quickly.

### Checking Elements

There are malfunctions simple and complex, the first can be dealt with on your own, the second is not so easy to eliminate.

## Fuse



It is located next to the thermostat. The thermal fuse protects the sole from serious overheating. A protective tube is put on a small device. It often has a white color. Checking the fuse — ringing its contacts. You can test directly by sliding the protection tube, or by finding the contacts in the circuit. If the case is a thermal fuse, then it is evaporated, sent to the store, taking it with you, and buy a similar device. Then set it in its original place. An exception to the fuse circuit is a big mistake, as it is able to protect the house from fire.

## Power cord



His gap is another common misfortune. Symptoms of damage — failure of the iron to turn on, intermittent operation of the device, insufficient heating of the sole. If suspicious areas are found, the cord should be replaced. Isolation of problem areas is the second option for repair, but it is not optimal. To check the hunch, the cord is also called. In this case, complete disassembly is not required, since it will be enough to remove the back cover to gain access to the terminal block. One probe of the multimeter is pressed to the contact of the plug, the other to the wire on the block. To make sure that all sections of the wire are working, they knead it during the test or try to bend it, twist it.

## Spray system



In this case, the master will not have to look for the answer to the question of how to disassemble the iron, since the problem is solved quite simply in most cases. If in the presence of water in the reservoir steam in normal quantities refuses to form, then, most likely, the holes in the sole are clogged with salts.

They clean the iron from scale in the following way: pour a solution of vinegar (per liter of water — a glass) or citric acid (per glass — a tablespoon) into a wide heat-resistant dish, put the iron with a steam regulator set to maximum. The platform must be covered with liquid by 1 cm. To keep the nose lower, coins are placed under the back of the sole.

The container is sent to the hotplate, the liquid is brought to a boil, then turned off for half an hour, and then turned on again. The operation is repeated 3-4 times. The result of this procedure — cleaning the holes — will be visible immediately, but for some time there may be traces on the laundry, the outgoing sediment is to blame for them.



The second way is safer. In this case, the iron is disassembled to the base — the soles. It is also put on gas in a container. Or glue it from below, and then fill in one of the proposed solutions. It is changed after complete cooling. When they get rid of scale, the sole is washed with clean water.

Another two potential problems are the disconnection of the tube through which water is supplied and the deformation of the tank. In the first case, the steam does not leave the sole at all. To remedy the situation, they disassemble the panel on which the injection button is installed, and all the tubes and wires are returned to their rightful place. With deformation (inflating) or rupture of the water tank, there is only one way out — buying a new iron.

### Thermostat



To check it, it is necessary to disconnect the plastic casing from the sole. The temperature controller consists of three parts: two plates — bimetallic and contact — and a rod attached to them. The first plate is in contact with the sole. When heated, it bends, at maximum temperature it opens the contacts. When cooling, the plate returns to its previous position, causing the sole to heat up again.

The first stage of verification is scrolling to different positions. If there is a click, then the regulator is in order. Now they check the availability of power supply — by the test of the contacts with which the heater is connected to the regulator. If the multimeter makes a squeak in the dialing mode, and is silent in the other (extreme) position, then that means that everything is normal.

Sometimes the contacts burn out, oxidize or weaken. Clean them with sandpaper or a nail file. Do the operation carefully, trying not to bend the plates, not to remove a large layer. If the regulator has lost its smooth running and it is possible to crank it with effort, then it is rotated several times in different directions using pliers. The designed unit is rubbed with a graphite pencil stick. After all repairs, but before assembling the iron, contact is checked again.

### TEN

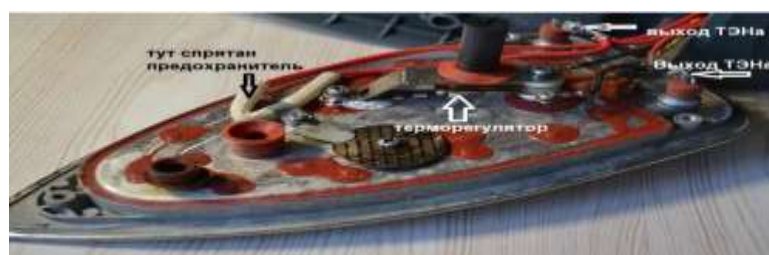

This is the most unpleasant breakdown, since manufacturers often solder the heater in one housing with a sole and a water tank. Therefore, a malfunction in one of these nodes ends with the purchase of a new device. There is a small percentage of exceptions: the sole can be saved if strong contact oxidation has occurred. In this case, they are sought, cleaned, crimped.

Check the heater by measuring the resistance. For irons, electric heaters are used that have a resistance of about several tens of ohms, it depends on the power. A more accurate figure is found in the passport of the device. If the resistance is in the range of 25-50 Ohms, the device is serviceable. When the multimeter shows  $\infty$ , things are bad — the heating element has burned out, but there is little sense in replacing it.

### **Safety Precautions**

A steam iron is an electrical appliance that also comes in contact with water, so caution when disassembling such dangerous equipment is required. Before starting work, disconnect the iron from the power supply, and only then drain all the water. If serious problems are found precisely in the electrical part, then it is better to immediately contact a service center.



Since it is not very difficult to disassemble the iron, many consider it their duty to find and fix the problem on their own. However, this does not happen in all cases, so it is sometimes much easier to buy a new device than trying to reanimate the old one with your own hands. The same applies to his repair in the workshop. The costs fully justify the purchase of a new iron, to which the owners should already be treated with «reverence.» First of all, this concerns the recommendations of manufacturers, as well as the use of the cleanest water for the device.

### **Prevention of ironing problems**

So that the owners do not have to learn how to disassemble the iron, how to repair it on their own, it is better to strictly follow some recommendations that can prevent possible breakdowns. The long service life of the unit can be expected if:

- always check the surface of the sole — remove adhering debris and small fibers;



- do not clean the iron with completely unsuitable compounds, such as salt;
- prevent overheating of the equipment, do not leave it alone;
- do not attempt to repair wireless devices yourself;
- abide by the recommendations that all things are provided with;
- do not iron products with a pile without gauze using steam;
- do not leave the iron wet or damp;
- absolutely not allow him to fall.



Cleanliness, constant supervision and careful handling will eliminate breakdowns and save money. And if nevertheless the trouble happened, it is better to first see how experienced disassemblers advise how to disassemble the iron.

### Assembling and Dismantling of electric geyser

The water geyser silently plays an important role in our life. We all deserve a good hot long shower after a long and tiring day and a Water heater is something that nobody wants to malfunction. Imagine standing in front of the shower and suddenly feeling the cold water on the body instead of hot.

Repairing water heaters could be a pain, we don't want to call the plumber and ask them to come again and again for water heater repair. To avoid that chaos, we can follow some easy, quick yet guaranteed steps that will help you avoid geyser repair.

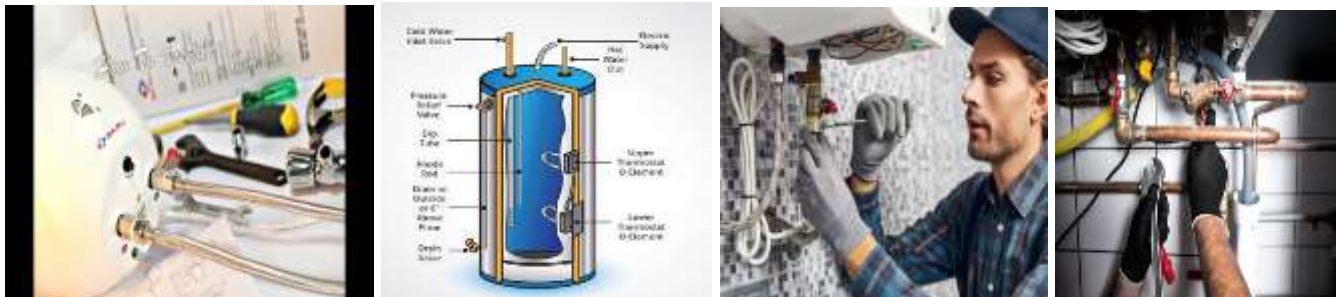

### Water Heater Repair: Common problems

**1) No Hot Water-** No hot water is a clear sign that there are some serious issues with the water heater and you need to repair water heater as soon as possible.

**2) Little Hot Water-** Some people might ignore it which they shouldn't. If you think that the heater is not warming enough water then you should get it repaired as it could lead to no hot water in the future.

**3) Leaks:** One must not avoid drips or sprays of water coming out from the water heater or even rust or some white-coloured deposits, this could be a serious issue and needs to be fixed at the earliest.

**4) Smelly water:** The bad odour originates from the bacteria growing on the sediment inside the tank. Drain and clean the tank as soon as you smell a bad odour.

**5) Unusual Sounds:** Sounds like loud pops are unusual and can result in being torn down to become sediment. If you hear any unusual sound, ask a plumber to check it as it might be dangerous.

### What to do when the water stinks?

The main reason behind the foul-smelling is bacterial decomposition or anode rod that makes the water stink very badly. Getting rid of this smell is not a tough task. Gently clean the water tank with a diluted hydrogen peroxide solution and if the water still stinks then the best option is to replace the anode rod.

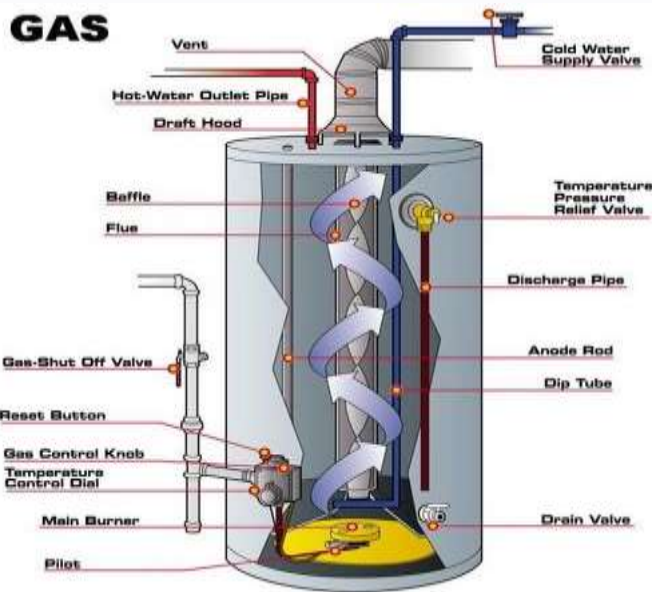

### Water Heater Repair Tips:

1. *Install heater at sufficient height:* According to experts, a water heater should be installed at a height of at least 1.8 meters or 6 feet from the ground. As it empowers the pressure of water and you get warm water.
2. *Drain the water heater:* Collect the water while draining the water heater and you can see that it will be full of sediments. If the water heater is not drained timely then, the sediment will get collected and could cause a serious issue.



3. *Inspect the pressure-relief valve:* Checking the pressure relief valve or thermostatic mixer for clogs could help you in sensing if there's an issue in the water heater or not. You can check the pressure once a year to avoid big damage.
4. *Monitor water temperature:* You must monitor the water temperature from time to time. The hot water temperature should be 125 degrees or lower, it should not go beyond that.
5. *Focus on the exhaust stack:* One must look closely and make sure that the connections are safe and there is no leakage in the water heater. Also, if there's any rust or corrosion, make sure to sort that out as this can create a problem in the future.
6. *Old Is Not Always Gold:* If your water heater is more than 10 years old then you should go for a new one as the 10-year-old unit can never compare to today's technology so you must buy a new one as it will work much more efficiently. Another major benefit of replacing the water heater will be that it'll lower the electricity bill way more than a 10 year old one.
7. *Examine the insulation:* One must check the insulation around the unit after every few months. You must cover the water heater with insulation, particularly if the unit is older. It will not only lower the electricity bill but will also keep the water hot as the unit does not have to run much.
8. *Electrical Connections & wiring:* Make sure that the water heater is wired to an MCB i.e., Miniature Circuit Breaker which cuts off if there is any instability in the power.
9. *Annual maintenance:* To avoid a big problem with your heater, make sure you get regular annual checkups done. If the problem gets detected at the initial stage it can easily be rectified.
10. *Lower the temperature:* Temperature lowering will not only save electricity but will also increase the lifespan of the geyser as the lower temperature will reach the desired temperature faster/ Apart from this, warm water will decrease the chances of accidental burns rather than hot water.



If you want to go for eco-friendly water heaters, then electric water heaters are the options to go for. A tankless water heater heats the water only when you are using it and does not operate constantly, which is an excellent way to save electricity.

### **Dismantling and assembling of table fan**

Electric fans are an easy and budget-friendly solution to beat the heat. However, table fans are even more convenient and handy to circulate air around your house. Although you look for the best features before buying a table fan, it is common for these machines to stop working or make jittering sounds due to many reasons. Worry not, about how you are going to repair it. Here are a few simple and easy hacks for table fan repair.

Sometimes, the fan might be in a good condition, but does not work due to a faulty switchboard connection. To avoid making a quick decision about your fan, as a first step of the repairing process, check your switchboard connection. If there are any issues in it try fixing the switchboard yourself.

### **Clean your table fan**

If your table fan is noisy, then it could be the dust particles that have accumulated in the parts of the fan. This is a common problem that arises due to continuous usage of table fans. Cleaning your fan is a simple solution to the problem. First of all, unplug the power cable as you might get an electric shock and remove the clamps on the outer side of the fan. Detach the blades by rotating the knob. Now that you have dismantled all the parts of the fan, clean them completely with a damp cloth. However, remember to not dip the parts in water. Once you have thoroughly cleaned the parts, reassemble the elements in order. Finally, check if your fan is operating smoothly.

### **Lubricate the shaft bearings**

Table fans can make rattling sounds due to the friction between the bearings. An easy method to solve this issue is by oiling the bearings. The process is as simple as cleaning the fan. Start by detaching all the parts of the table fan. After removing the blades, carefully apply lubricating oil to the bearings. This could be any household oil. However, make sure you do not spray oil into the motor. Once this is done, arrange back all the parts and test if the fan is working fine.

### **Change the capacitor**

Sometimes, no matter how much you clean or lubricate your table fan, there is a possibility that the problem is not just dust and friction. In such a scenario, it is time to find an alternate approach. Begin by removing all the parts of the fan separately. Take a look at the capacitor that is connected and buy the same model. Cut the wires that is connected to the current capacitor and replace it with the new version in the same type. Rearrange the parts and plug in the socket to check if the motor rotates. Be

careful while carrying out this process. Make sure you have switched off the fan before removing the parts and leave it untouched for some time as the inner coils will be heated up.

### **Replace the thermal fuse**

Now that you are aware of how to dismantle the parts of a table fan, remove the motor from the unit. You will be able to see different coloured wires in the shaft. Disconnect the ground and neutral wires from the terminal. Refer to the user manual for the colour codes of the wires. Trace down the neutral wire to find the sheath that holds the fuse. Carefully solder the new fuse in the right polarity by keeping the other parts intact. Although this seems to be easy, the process requires expertise and care. At this stage, it is better to outsource the work to professional electricians or people who know the technicalities.

### **Realign the metal coil**

Sometimes a table fan might not stay in a fixed position due to the metal coil getting frequently displaced. This is a common scenario, especially when the fan has been used for a long time. However, the process to realign the metal coil is fairly simple and can be done at home. Begin by dismantling the parts of the fan, by unplugging the main power source and slowly unscrewing and removing the clamps. Once this is done, all you need to do is take the black holder and open the knob in the holder. Then, loosen the required clamps. You will see the metal coil under the dismantled shaft. Realign it in the correct place and assemble all the parts of the table fan that were dismantled. Finally, check if your table fan works fine. The wobbling effect should have drastically reduced.



### **What do you need for a table fan repair?**

You do not require any fancy or expensive apparatus to repair a table fan. All you need is to have a screwdriver to open the fan blade covering. It is also handy to have a cloth to clean the nooks and corners of the parts of the fan. In case your capacitor is faulty, you would require a new capacitor. However, it is important to check the specifications before buying one. Changing the thermal fuse

would be the last step of the procedure. You will have to buy a new fuse in case of changing one. It is always better to have a spare of best quality wires to avoid the last minute rush.

### **Benefits of repairing a table fan yourself**

‘Do it yourself’ is booming in today’s world. It encourages personal involvement and motivates you to develop a new skill. Repairing a table fan by yourself is also one form of DIY as you circumvent expert help with a pool of other benefits. The first obvious benefit is about saving money. All that you need to spend is for spare parts, and a considerable amount is saved from paying for the service.

Additionally, you can also buy the spare parts depending on your choice. However, it is important to invest in branded spare parts for minimal maintenance and long shelf life. To add to that, it is more convenient to do it yourself as there is no waste of time in sourcing the technician. Moreover, you attain a sense of satisfaction and accomplishment. Now you know where and what went wrong, you can be proud of the new skill that you have mastered! This is a way of encouraging yourself to do things on your own. Even after trying your hands on these easy hacks for table fan repair, if your fan does not work, then it is time to look out for a new pedestal or table fan.

### **Dismantling and assembling of ceiling fan**

The most common appliance in any Indian household is the ceiling fan. A must-have, and needed in all-weather conditions, especially during Indian summers. Like with all appliances, there is always a wear and tear. Regular maintenance, repairs, parts replacement or even complete replacements may occur. Would it not be great if all appliances once installed continue to perform as intended to, without any break-down.



### **Ceiling fan repair techniques**

#### **Fan becomes wobbly or makes more noise than normal when in use**

- First, make sure the canopy isn't touching the fan motor housing.
- Fasten the blade screws if loose.
- Rebalance the fan blades if needed.

- In case any of the blades are damaged, replace them.
- If the above points do not eliminate the wobble or the extra noise, then the bearings might have worn out. So, lubricate or replace them.

### **The Fan is Not Rotating**

- Eliminate power supply problems.
- First, make sure the circuit breaker is on and is receiving electrical power.
- Switch it off & then switch it on to reset it.
- Switch on the fan again.
- If it still doesn't start, check whether the power supply is reaching the fan motor using a voltage tester. If that's an issue, check for a faulty regulator or switch and replace them.
- If everything is working and the problem persists, then you might have to replace the capacitor.
- Even if this does not work, the motor and winding are might be causing the issue. Repair or replace them.



### **Speed issues**

- For this, you might have to replace the regulator or capacitor



## Experiments

### 1. Dismantling and assembling of steam iron box

#### **Aim:**

1. To dismantle and assemble the steam iron box.
2. To know the parts of the appliance.
3. To learn about various defaults and remedial measures.

#### **Additional information**

An iron box is the household appliance and commonly used by all people. From child to elders, all are not wearing the dress without ironing. This appliance plays a vital role in the modern world.

Electric Iron box is classified into three types.

- a. Simple or ordinary iron box
- b. Automatic iron box
- c. Steam iron box.

#### **a. Simple or ordinary iron box**

Now a day an ordinary iron box is not used.

#### **b. Automatic iron box**

##### **1. Parts Description:**

#### **i) Sole plate**

The sole plate is the base plate of the iron box, which is in the bottom side and is laminated with nickel or chromium to make the surface shining. There are two threaded holes at the top of the sole plate, in which heating element and pressure plate are kept and got fitted with top cover of the iron box.

#### **ii) Heating element**

The heating element is made up of Nichrome, the metal alloy which is completely wound inside the mica sheet.

#### **ii) Pressure plate**

The pressure plate is made up of a cast iron plate of the shape of heating element. Its size is slightly larger than the heating element. It keeps the heating element in a compact and stationary, when the iron box is in motion.

#### **iv) Top cover**

It is made up of a sheet cover used to cover heating element and pressure plate of the iron box including electrical connection.

#### **v) Handle**

It is made up of Bakelite, nonconductive material fitted over the top cover used for handling the iron box.

#### **2. Automatic iron box working principle**

An automatic electric iron box is fitted with a thermostat which controls the temperature automatically. Thermostat is a bi-metallic strip which bends when the temperature exceeds the setting

limit. An adjustable setting screw or setting knob sets the temperature that should be maintained by the thermostat control.

### 3. Steam iron box

Steam iron box is similarly same as that of an automatic iron box. In this type, a small water container is provided above the heating element, wherein which water is supplied to sole plate through the holes provided. A valve is provided to control the water flow and steam.

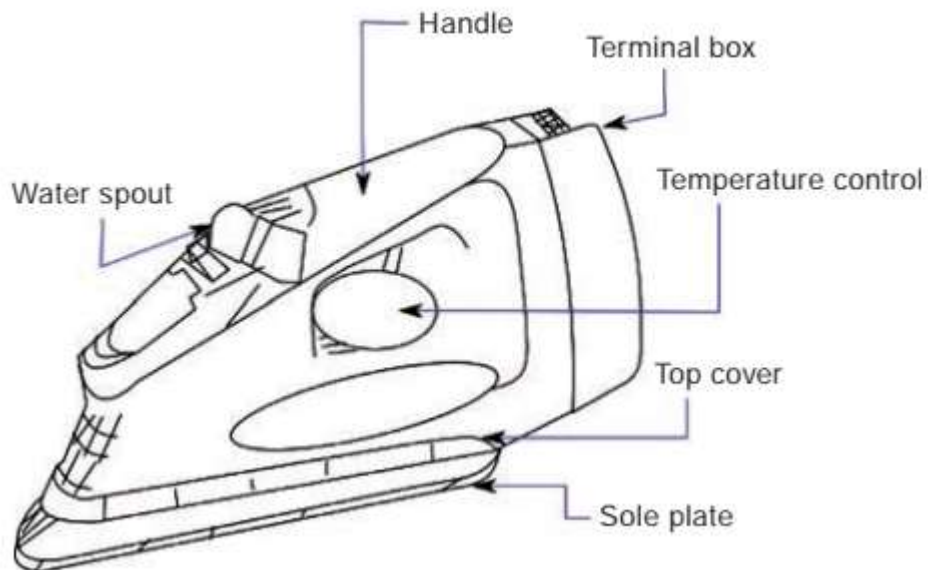

#### Tools and materials required

1. Electric steam iron box
2. Electrical tools kit
3. Test lamp
4. Megger
5. Multimeter
6. Voltmeter (0 – 250 volts)

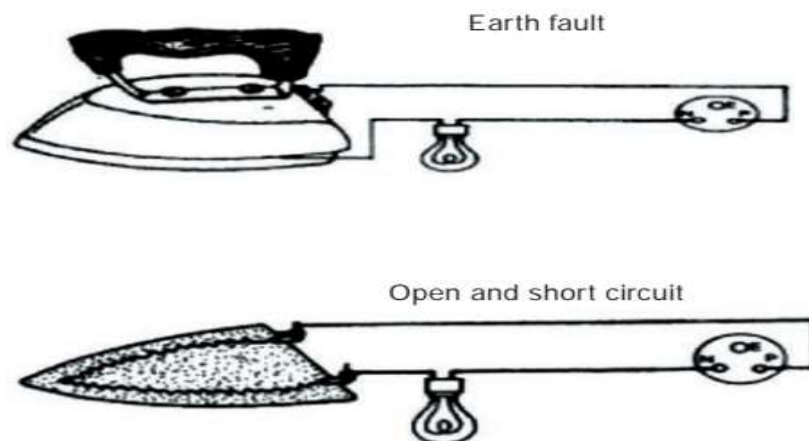

#### Dismantling procedure

1. Electrical connection of the steam iron box should be removed from the supply.





## **2. Dismantling and assembling of an electric geyser**

### **Aim:**

1. To dismantle and assemble an electric geyser
2. To examine the various parts of an electric geyser
3. To study the construction and working principle of geyser
4. To find out the various faults in the geyser

### **Related information**

An electric geyser is an appliance used to heat water with electric supply. Generally electric geysers are available with the capacity of 5, 10, 15, 25 and 50 liters. The ratings of the geyser are ranging from 500 watts to 2000 watts. The inner tank of the electric geyser is made up of copper with tinned coating in the inner side. In some other geyser, the tanks are made up of steel with nickel coating inside. The outer side of the geyser is made up of metal and painted to avoid rusting.

In order to protect the hotness of the water including heat loss inside the tank, a metallic cover is provided around it. Between inner and outer tank 8cm wide space is left around the tank, in which filled with glass wool. This glass wool acts as the heat insulation for the geyser.

According to the capacity of the geyser, various size and type of heating elements are used. Commonly tubular type of heating element is used in geyser. The heating element is fitted inside the tube which is filled with magnesium oxide. This magnesium oxide acts as an insulator and prevents the element from touching inside the wall of the tube. The bottom head of the tube is fitted with Bakelite which is fitted with connecting pins of the heating element. The heating element, thermostat and indicating lamp are fitted in the bottom cover as in figure below.

The hot water outlet pipe is arranged in siphon manner, so that the initial water level must reach level 'A'. The water level cannot be reduced below level 'B' which ensures that the heating element will always be inside the water.

The thermostat fitted in the geyser controls the temperature of the water automatically and thus, safeguards the whole unit from overheating. As soon as the temperature of the water inside the tank reaches to the temperature of 85 degree, the heating element is automatically disconnected. Electric connection is restarted as soon as the temperature of the water falls. According to the size and capacity of a geyser, the power consumption varies. A typical rating for a geyser is 230 to 250 volts.

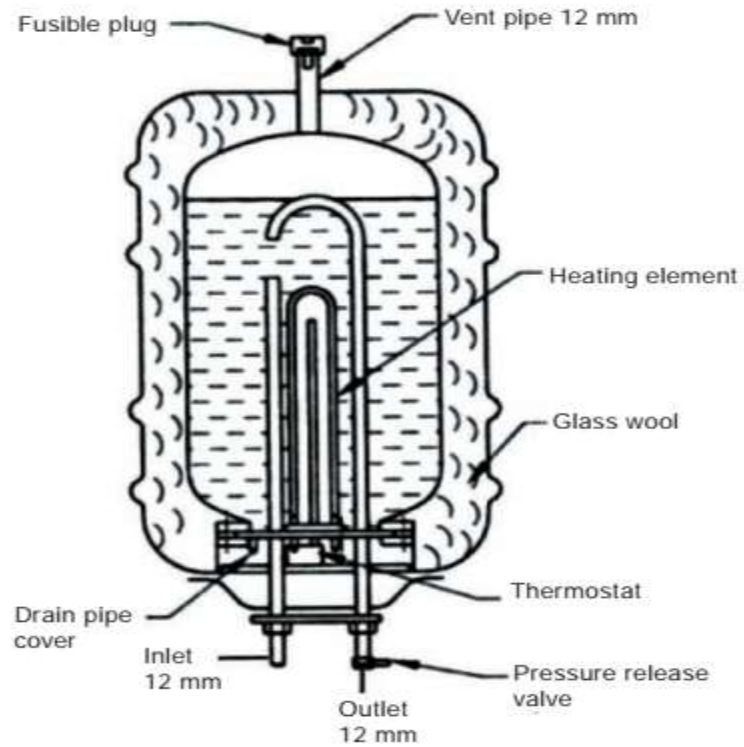

**Hand tools and apparatus required**

S. No.	Hand tools and apparatus required	Quantity
1.	Electric geyser	1
2.	Tools box	1
3.	Tester	1
4.	Megger	1
5.	Multimeter	1

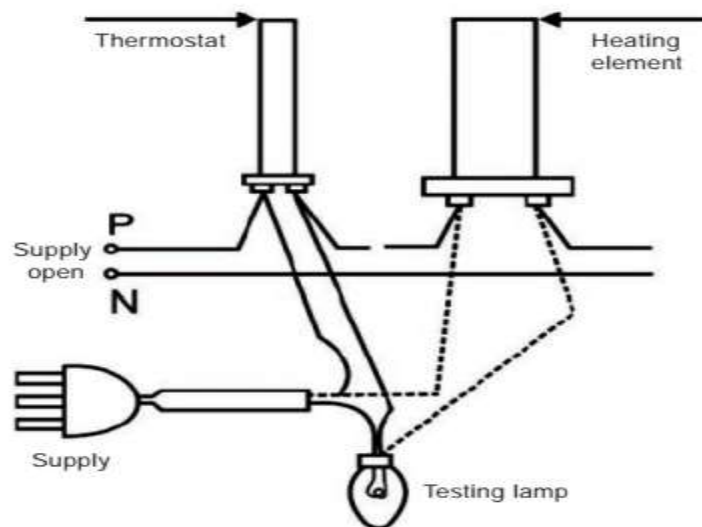

**Connection diagram of an electric geyser**

### **Dismantling procedure**

1. Disconnect the main supply of the geyser.
  2. Drain out the stored water from the geyser.
  3. With the help of Megger, test the leakage in the appliance.
  4. Remove the bottom cover which contains heating element, thermostat and indicating lamp.
  5. Remove the earth connection from the body of the geyser.
  6. Remove the fitting clamps of the geyser.
  7. Check the continuity of the heating element.
  8. After removing the heating element, clean the scale formation by using hydro chloric acid solution.
- After verification of all these above, ensure that all the parts and materials of the geyser are in good condition.

### **Assembling procedure**

1. Check if the geyser is clean and fit it with clamps.
2. Connect the earth wire with the body of the geyser.
3. Fit the bottom cover of the geyser properly. (In this heating element, thermostat and indicating lamp are fixed)
4. With the help of Megger, check out the electrical leakage, if any.
5. Then connect the electrical supply to the geyser and make sure that it was connected properly and firmly.

### **Observations made after completion of installation or fitting of the geyser**

1. After installation of the geyser, open the inlet tap of the control valve, until the water tank is filled.
2. Switch 'on' the supply and wait for few minutes and then open the hot water tap.
3. Check the continuous flow of warm water is coming properly.
4. Close the tap of hot water when not in use and turn off the supply

	<b>Open circuit</b>	<b>Short circuit</b>	<b>Earthing</b>
Test lamp	Won't glow / Glow	Bright / Dim	Glow / Won't glow
Fault	Occurred / Not occurred	Occurred / Not occurred	Occurred / Not occurred

**Observation record**

- a. Voltage of the geyser :
- b. Storage capacity of the geyser :
- c. Power supply of the geyser :
- d. Frequency supply of the geyser :
- e. Current of the geyser :
- f. Fuse rating :

**Precautions**

1. Do not touch the geyser, when the power supply is 'ON'.
2. Check the body of the geyser is electrically insulated, before and after dismantling of the geyser.
3. Before switching 'ON' the electric supply, ensure that the inner water tank of the geyser is filled with water.
4. After completion of the necessity of hot water, disconnect the electrical supply of the geyser.
5. When the geyser is not to be used for a long time, the water in the tank should be drained out by unscrewing the drain plug.

**Result**

The method of dismantling the given Geyser and identify the parts, testing the Geyser, identifying and rectifying its faults, and assembling the Geyser was carried with proper tools. Now the Geyser is working in good condition.

### 3. Table fan

#### Aim:

1. To dismantle the given table fan and identify the parts.
2. Testing the table fan, identifying and rectifying its faults, and reassembling the table fan
3. Test the table fan with supply and run it.

#### Related information

Normally, the sweep of the table fan is available in 220mm, 300mm and 350mm. In some table fans shaded pole motors are used. Generally permanent capacitor induction run motors are used. Table fans are used to circulate the air to the required area. The blades are mounted on the rotating shaft. The blades are covered with a cage for safety purposes. In a table fan the motor is placed at the top of the body and the regulator is fitted on the base. The power consumption of the table fan is 60 watts.

#### Apparatus Required

S. No.	Equipment	Quantity
1.	Table fan	1
2.	Insulation tape	1
3.	Grease	1 pocket
4.	Kerosene	100 ml
5.	Bearing Puller	1
6.	Waste cotton	Required quantity
7.	Wooden board	Required quantity

#### Practical procedure: Dismantling

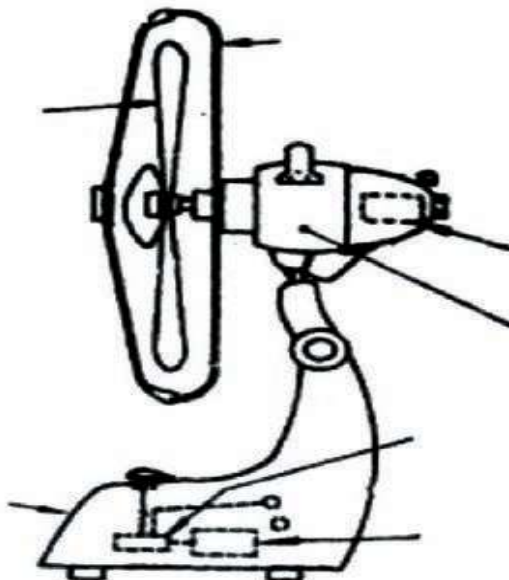

- i. Open the clips of the cage
- ii. Cage should be kept separately
- iii. Unscrew the blade mounting screws and remove the blades from shaft
- iv. Unscrew the back cover and remove it
- v. Take out the gear box by removing the mounted screws
- vi. Remove the rotor and keep separately

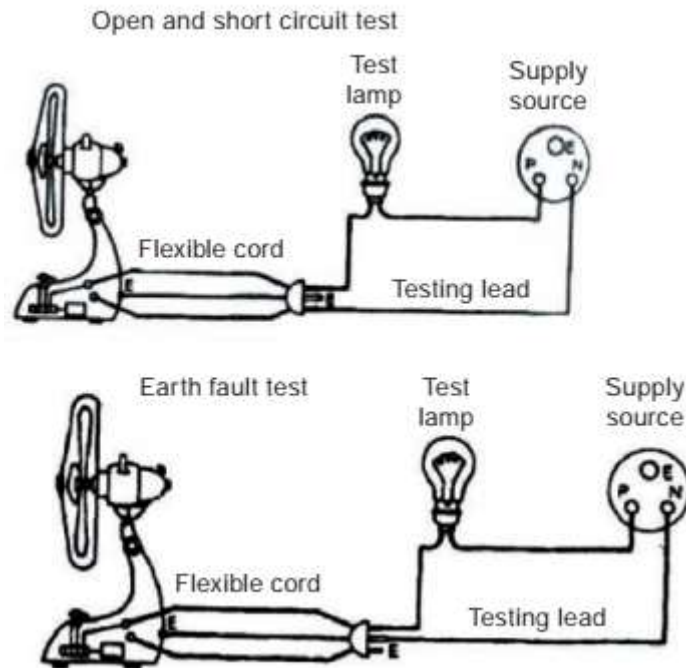

Rotor shaft and bearing are cleaned with kerosene and waste clothes. Clean the rotor carefully without damaging the coils. The stator winding is tested with the use of test lamp. Test the capacitor and check whether it is in good condition.

### Assembling

- i. Fix the back side end cover of the rotor and gear box properly
- ii. Fit the blades and cage in front side properly
- iii. Open circuit test, short circuit test and earth test is to be done by test lamp

### Testing procedure

- i. Connect the test lamp to the two terminals of the table fan. If the lamp glows dim, it means the table fan is in good condition. If it glows brightly, it means short circuit fault occurs and the lamp does not glow, it means open circuit fault occurs in the table fan.
- ii. Connect the one lead of the test lamp to the one terminal of the table fan and



connect the other lead of the test lamp to the body of the table fan. If the test lamp glows, it means earth fault occurs in the table fan.

	Open circuit	Short circuit	Earthing
Test lamp	Won't glow / Glow	Bright / Dim	Glow / Won't glow
Fault	Occurred / Not occurred	Occurred / Not occurred	Occurred / Not occurred

### Precaution

- i. Do not use hammer when dismantling and assembling the parts
- ii. Handle the bearings carefully
- iii. Conduct the test carefully

### Result

The method of dismantling the given table fan and identify the parts, testing the table fan, identifying and rectifying its faults, and assembling the table fan is carried with proper tools. Now the table fan run with normal speed and it is in good condition.

## 4. Ceiling fan

### Aim:

1. To dismantle the given ceiling fan and identify the parts
2. To test the ceiling fan, identify and rectify its faults, and assemble the ceiling fan

### Related information

The information of a ceiling fan is obtained from name plate which is fixed on the body of the fan. It helps us to know details of the fan correctly. Generally in ceiling fan, permanent capacitor induction run motor is used. The inner portion of ceiling fan is stator. The outer rotating portion is rotor. Ceiling fan is fitted in the ceiling by conduit metal pipe. When the power supply is given, the blade of the fan rotates and air is circulated around the area where the fan is connected. Regulator is connected in series with the motor to control the speed.

### Tools required

S.No.	Hand tools	Quantity
1.	Insulated cutting plier	1
2.	Insulated screwdriver 15cm	1
3.	Insulated screwdriver 25 cm	1
4.	Test lamp	1
5.	Spanner set	1

### Apparatus required

S.No.	Equipment	Quantity
1.	Ceiling fan	1
2.	Insulation tape	1
3.	Grease	1 pocket
4.	Kerosene	100 ml
5.	Bearing puller	1
6.	Waste cotton	Required quantity
7.	Wooden board	Required quantity

### Practical procedure: Dismantling

- i. Separate the fan from ceiling clips.
- ii. Unscrew the screws in canopy.
- iii. Remove the condenser from its housing.
- iv. Remove the blades from the fan.
- v. Remove the cover, separate the stator and rotor.

### DO's after dismantling:

Rotor shaft and bearing are cleaned with kerosene and waste clothes. Clean the rotor carefully without damaging the windings. The stator winding is tested with the use of test lamp. Test the capacitor and check whether it is in good condition.

**Assembling**

- i. Fix the end covers with stator
- ii. Connection is given to the windings and capacitor
- iii. Open circuit test, short circuit test and earth test is to be done by test lamp

**Testing procedure**

- i. Connect the test lamp to the two terminals of the ceiling fan. If the lamp glows dim, it means the table fan is in good condition. If it glows brightly, it means short circuit fault occurs in the ceiling fan and if the lamp does not glow, it means open circuit fault occurs in the ceiling fan.
- ii. Connect the one lead of the test lamp to the one terminal of the ceiling fan and connect the other lead of the test lamp to the body of the ceiling fan. If the test lamp glows, it means earth fault occurs in the ceiling fan. Otherwise earth fault does not occur in it.

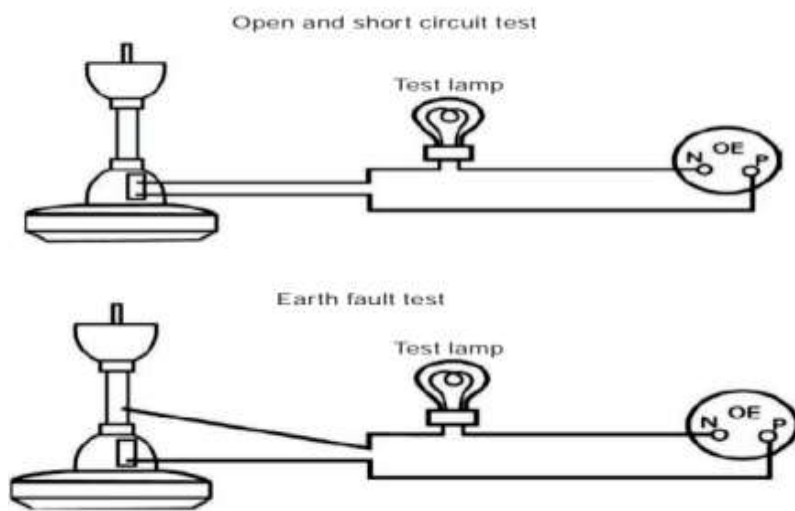

	<b>Open circuit</b>	<b>Short circuit</b>	<b>Earthing</b>
Test lamp	Won't glow / Glow	Bright / Dim	Glow / Won't glow
Fault	Occurred / Not occurred	Occurred / Not occurred	Occurred / Not occurred

**Precautions**

- i. Do not hammer use while dismantling and assembling the parts
- ii. Handle the bearings carefully
- iii. Conduct the test carefully

**Result**

The method of dismantling the given ceiling fan and identify the parts, testing the ceiling fan, identifying and rectifying its faults, and assembling the fan is carried with proper tools. Now the ceiling fan run with normal speed and it is in good condition.

**Write the observations and experiences**

**Batteries and their applications:**

Different types of batteries and their applications

Working of lead acid battery

Charging of the battery

Experiments:

- 1) Physical demonstration of battery
- 2) Testing of lead acid battery
- 3) Charging of lead acid battery

**What are the Different Types of Batteries?**

In this tutorial, we will learn about one of the important components in electrical and electronic systems: A battery. We will see some basic information about a battery, take a look at different types of Batteries and also a guide on what battery type is suitable for your application.

**Introduction**

Whether you are an electrical engineer or not, you might have come across at least a couple of different types of batteries in your life. Some of the common places where you use batteries are a wall clocks, alarms or smoke detectors, which use small disposable batteries or cars, trucks or motor cycles, which use relatively large rechargeable batteries.

Batteries have become a very important source of energy in the last decade or so. Even before that, they were an integral part of our lives in powering several portable devices like transistor radios, Walkman, handheld games, cameras etc.

But with the development in advanced smart phones, tablets, laptops, solar energy and electric vehicles, the research into powerful batteries that can last longer and can deliver the necessary energy has been at its peak.

As a matter of fact, the 2019 Nobel Prize in Chemistry has been awarded to three scientists John B. Goodenough, M. Stanley Whittingham and Akira Yoshino for the development of lithium-ion batteries.

**What is a Battery?**

A Battery is a chemical device that stores electrical energy in the form of chemicals and by means of electrochemical reaction; it converts the stored chemical energy into Direct Current (DC) electric energy. Alessandro Volta, an Italian Physicist, invented the first battery in 1800.

The electrochemical reaction in a battery involves transfer of electrons from one material to another (called electrodes) through an electric current.

## Different Types of Batteries

Electrochemical cells and batteries are categorized into two types. Although there are several other classifications, these two are the basics:

- Primary (non-rechargeable)
- Secondary (rechargeable)

Primary batteries are non-rechargeable ones. This means they can't be recharged with electricity.

The secondary batteries work otherwise. They're ideal for recharging.

### Primary batteries

A primary battery is a convenient source of power for portable electronics and devices. This includes radios, watches, toys, lights, camera, and more.

Since they can't be recharged once they run out of power, they're the type to *"discard immediately when discharged"*. **In short, they can't be used again.**

Primary batteries are inexpensive, lightweight, and convenient to use with no maintenance. The majority used in domestic applications are single cell type.

They usually come in a cylindrical form, such as *Alkaline batteries*. They got their name from the electrolyte used in them: potassium hydroxide—a pure alkaline substance.

This type of primary battery is a chemical composed of zinc (Zn) and manganese dioxide (MnO<sub>2</sub>). It has a power density of 100 Wh/kg.

Other shapes and sizes of a primary battery include a coin-shaped one, a.k.a. *coin cell batteries*. They are often used in torches, remotes, wall clocks, small portable gadgets, and more.

The chemical composition of a coin cell battery is also alkaline. But it also contains lithium and silver oxide chemicals.

These compounds make this small battery more efficient, providing steady and stable voltage. It has a power density of 270 Wh/kg.

**Other types of primary batteries include:**

<b>Battery Type</b>	<b>Characteristics</b>	<b>Applications</b>
Alkaline (Zn/Alkaline/MnO <sub>2</sub> )	Very popular, moderate cost, high performance	Most popular primary batteries
Magnesium (Mg/MnO <sub>2</sub> )	High capacity, long shelf life	Military and aircraft Radios
Mercury (Zn/HgO)	Very high capacity, long shelf life	Medical (hearing aids, pacemakers), photography
Lithium/Solid Cathode	High energy density, low temp performance, long shelf life	Replacement for button and cylindrical cells
Lithium/Soluble Cathode	High energy density, good performance, wide temp range	Wide range of applications with a capacity between 1 – 10,000 Ah
Lithium/Solid Electrolyte	Low power, extremely long shelf life	Memory circuits, medical electronics
Silver/Zinc (Zn/Ag <sub>2</sub> O)	Highest capacity, costly, flat discharge	Hearing aids, photography, pagers
Zinc – Carbon	Common, low cost, variety of sizes	Radios, toys, instruments

### **Secondary Batteries**

**The main advantage of these batteries is they can be recharged and reused.** Hence the other term: rechargeable batteries.

Secondary batteries usually cost more than primary ones. But considering they're rechargeable, they can have a longer lifespan.

#### **Used for two applications:**

- energy storage devices
- applications where the battery is used and discharged as a primary battery

In the first application, secondary batteries supply and store energy for devices such as:

- Uninterrupted Power Supplies (UPS)
- Hybrid Electric Vehicles (HEV)

This means they're used as energy storage devices where they're electrically connected to the main energy source. At the same time, they're charged by it, supplying the needed energy.

For instance, a UPS. It's a battery backup, especially for computers. It provides reserve power when your regular power source fails.

As for the second application, rechargeable batteries also work for portable electronics like:

- Mobiles
- Laptops
- Electric vehicles



Once they're completely or almost discharged, they can be recharged with a charging mechanism.

For example, smartphone batteries. Most models have a *lithium-ion battery* that lives longer when charged often.

This type of battery acts as their main power source, their *primary* one. But unlike the standard primary batteries, lithium-ion is rechargeable and reusable.

For one, instead of discarding it, you pull out your cable wire or charger then plug it into a socket to charge it.

Another great example is the *lead-acid batteries* found in most cars and vehicles. It comes with a nominal voltage starting from 2V to 24V with a 7 Wh/kg power density. Plus, it's considered one of the four major types of secondary batteries, along with lithium-ion.

Other major types of rechargeable batteries include:

- **Nickel – Cadmium Batteries.** One of the oldest battery types available today. They have a very long life and are also very reliable and sturdy.
- **Nickel – Metal Hydride Batteries.** They're a new type of battery, an extended version of Nickel – Hydrogen Electrode Batteries. Ideal use in aerospace applications (satellites).

### **Battery Applications**

Primary and secondary batteries are both used in a lot of appliances, such as:

- **Portable electronic devices:** Smart phones, watches, cameras, laptops, calculators, including testing equipment like multimeters.
- **Entertainment:** Radios, MP3 and CD players, infrared remote controls, toys and games, etc.
- **Household:** Smoke detectors, alarms, clocks, UPS, portable power tools, and more.

Choosing the right battery for your needs

Performance and cost are the main characteristics you should look for when buying batteries. On top of these two, you also might want to consider the following:

- Primary or secondary
- Energy or power
- Shelf life
- Energy efficiency and recharge rate
- Battery life
- Battery temperature

## Experiments

### 1. Physical demonstration of battery

#### **Cell and Battery**

Even though the term battery is often used, the basic electrochemical unit responsible for the actual storage of energy is called a Cell. A cell, as just mentioned, is the fundamental electrochemical unit that is the source of electrical energy produced by conversion of chemical energy.

In its basic form, a cell typically contains three main components: two electrodes and electrolyte and also consists of terminals, separator and a container. Speaking of electrodes, there are two types of electrodes called the Anode and the Cathode.

The Anode is the negative electrode (also called the Fuel Electrode or the Reducing Electrode). It loses electrons to the external circuit and in the electrochemical reaction, it gets oxidized.

Cathode on the other hand, is the positive electrode (also called the Oxidizing Electrode). It accepts electrons from the external circuit and in the electrochemical reaction, it gets reduced. Hence, the energy conversion in a battery is due to electrochemical oxidation-reduction reaction.

The third important component of a cell is the electrolyte. An electrolyte acts as medium for transfer of charge in the form of ions between the two electrodes. Hence, the electrolyte is sometime referred to as Ionic Conductor. An important point to be noted here that the electrolyte is not electrically conductive but just have ionic conductivity.

A battery often consists of one or more “cells” that are electrically connected in either a series or parallel configuration to provide the necessary voltage and current levels.

#### **Different Types of Batteries**

Basically, all the electrochemical cells and batteries are classified into two types:

- Primary (non-rechargeable)
- Secondary (rechargeable)

Even though there are several other classifications within these two types of batteries, these two are the basic types. Simply speaking, Primary batteries are non-rechargeable batteries i.e., they cannot be recharged electrically while the Secondary batteries are rechargeable batteries i.e., they can be recharged electrically.

#### **Primary Batteries**

A Primary Battery is one of the simple and convenient sources of power for several portable electronic and electrical devices like lights, cameras, watches, toys, radios etc. As they cannot be recharged electrically, they are of “use it and when discharged, discard it” type.

Usually, primary batteries are inexpensive, light weight, small and very convenient to use with relatively no or less maintenance. Majority of the primary batteries that are used in domestic applications are single cell type and usually come in cylindrical configuration (although, it is very easy to produce them in different shapes and sizes).

### Common Primary Battery Types

Up until the 1970's, Zinc anode-based batteries were the predominant primary battery types. During the 1940's, the World War II and after the war, Zinc – Carbon based batteries and they have an average capacity of 50 Wh / kg.

Most significant development in the battery technology took place during the 1970 – 1990 period. It is during this time, the famous Zinc / Alkaline Manganese Dioxide batteries were developed and they slowly replaced the older Zinc – Carbon types as the main primary battery.



Zinc – Mercuric Oxide and Cadmium – Mercuric Oxide batteries were also used during this period but due to the environmental concerns with respect to the usage of Mercury, these battery types slowly phased out.

It is during this period, where the development of batteries with Lithium as active anode material has been started and is considered a major accomplishment due to the high specific energy and longer shelf life of Lithium batteries over traditional Zinc batteries.

Lithium batteries are manufactured as button and coin cell for a specific range of applications (like watches, memory backup, etc.) while larger cylindrical type batteries are also available.

The following table shows different types of primary batteries along with their characteristics and applications.

Battery Type	Characteristics	Applications
Zinc – Carbon	Common, low cost, variety of sizes	Radios, toys, instruments
Magnesium (Mg/MnO <sub>2</sub> )	High capacity, long shelf life	Military and aircraft radios
Mercury (Zn/HgO)	Very high capacity, long shelf life	Medical (hearing aids, pacemakers), photography
Alkaline (Zn/Alkaline/MnO <sub>2</sub> )	Very popular, moderate cost, high performance	Most popular primary batteries
Silver/Zinc (Zn/Ag <sub>2</sub> O)	Highest capacity, costly, flat discharge	Hearing aids, photography, pagers
Lithium/Soluble Cathode	High energy density, good performance, wide temp range	Wide range of applications with capacity between 1 – 10,000 Ah
Lithium/Solid Cathode	High energy density, low temp performance, long shelf life	Replacement for button and cylindrical cells
Lithium/Solid Electrolyte	Low power, extremely long shelf life	Memory circuits, medical electronics

### **Secondary batteries**

A secondary battery is also called as Rechargeable Battery as they can be electrically recharged after discharge. The chemical status of the electrochemical cells can be “recharged” to their original status by passing a current through the cells in the opposite direction of their discharge.

Basically, secondary batteries can be used in two ways:

- In the first category of applications, the secondary batteries are essentially used as energy storage devices where they are electrically connected to a main energy source and also charged

by it and also supplying energy when required. Examples of such applications are Hybrid Electric Vehicles (HEV), Uninterrupted Power Supplies (UPS), etc.

- The second category of applications of secondary batteries is those applications where the battery is used and discharged as a primary battery. Once it is completely discharged (or almost completely discharged), instead of discarding it, the battery is recharged with an appropriate charging mechanism. Examples of such applications are all the modern portable electronics like mobiles, laptops, electric vehicles, etc.

Energy density of secondary battery are relatively lower than that of primary batteries but have other good characteristics like high power density, flat discharge curves, high discharge rate, low temperature performance.

### **Common Secondary Battery Types**

Two of the oldest batteries are in fact secondary batteries called the Lead – acid batteries, which were developed in late 1850's and Nickel – Cadmium batteries, which were developed in early 1900's. until recent times, there are only two types of secondary batteries.

The first and the most commonly used rechargeable batteries are called Lead – acid batteries. They are based on the Lead – Lead Dioxide (Pb – PbO<sub>2</sub>) electrochemical couple. The electrolyte used in these types of batteries is the very common Sulfuric Acid.

The second type of rechargeable batteries is called Nickel – Cadmium batteries. They are based on Nickel Oxy hydroxide (Nickel Oxide) as the positive electrode and Cadmium metal based negative electrode. Coming to the electrolyte, an alkaline solution of Potassium Hydroxide is used.

In the recent decades, two new types of rechargeable batteries have emerged. They are the Nickel – Metal hydride battery and the lithium – Ion battery. Of these two, the lithium – ion battery came out to be a game changer and became commercially superior with its high specific energy and energy density figures (150 Wh / kg and 400 Wh / L).

There are some other types of secondary batteries but the four major types are:

- Lead – Acid batteries
- Nickel – Cadmium batteries
- Nickel – Metal hydride batteries
- Lithium – Ion batteries

Let us now briefly see about these battery types individually.

### ***Lead – Acid batteries***

The lead-acid batteries are by far the most popular and most used rechargeable batteries. They have been a successful product for more than a century. Lead-acid batteries are available in several different configurations like small sealed cells with capacity of 1 Ah to large cells with capacity of 12,000 Ah.

One of the major applications of lead-acid batteries are in the automotive industry as they are primarily used as SLI Batteries (Starting, Lighting and Ignition).

Other applications of lead-acid batteries include energy storage, emergency power, electric vehicles (even hybrid vehicles), communication systems, emergency lighting systems, etc.

The wide range of applications of lead-acid batteries is a result of its wide voltage ranges, different shapes and sizes, low cost and relatively easy maintenance. When compared to other secondary battery technologies, lead-acid batteries are the least expensive option for any application and provide very good performance.

Electrical efficiency of lead-acid batteries is between 75 to 80%. This efficiency value them suitable for energy storage (Uninterrupted Power Supplies – UPS) and electric vehicles.

### ***Nickel – Cadmium batteries***

The Nickel – Cadmium Batteries or simply Ni-Cd Batteries are one of the oldest battery types available today along with the lead-acid batteries. They have a very long life and are very reliable and sturdy.



One of the main advantages of Ni-Cd Batteries is that they can be subjected to high discharge rates and they can be operated over a wide range of temperatures. Also, the shelf life of Ni-Cd batteries is very long. The cost of these batteries is higher than lead-acid batteries on per Watt-hour basis but it is less than other types of alkaline batteries.

As mentioned earlier, the Ni-Cd batteries use Nickel Oxy hydroxide (NiOOH) as Cathode and Cadmium metal (Cd) as anode. Typical consumer grade batteries come with an open-circuit voltage of 1.2V.

In industrial applications, Ni-Cd are just second to lead-acid batteries due to their low temperature performances, flat discharge voltage, long life, low maintenance and excellent reliability.

Unfortunately, there is one major characteristic of Ni-Cd batteries called the “memory effect”, which is their only disadvantage. When Ni-Cd cells are discharged partially and then recharged, they lose their capacity progressively i.e., cycle-by-cycle. “Conditioning” is the process where the lost capacity of the batteries can be restored.

In this process, the cells are completely discharged to zero volts and then fully recharged.

### ***Nickel – Metal Hydride batteries***

These are relatively new type of batteries are an extended version of Nickel – Hydrogen electrode batteries, which were exclusively used in aerospace applications (satellites). The positive electrode is the Nickel Oxyhydroxide (NiOOH) while the negative electrode of the cell is a metal alloy, where hydrogen is stored reversibly.



During charge, the metal alloy absorbs the hydrogen to form metal hydride and while discharge, the metal hydride loses hydrogen.

One main advantage of Nickel-metal hydride batteries over Ni-Cd batteries its higher specific energy and energy density. Sealed Nickel-metal hydride batteries are available commercially as small cylindrical cells and are used in portable electronics.

### ***Lithium – Ion batteries***

The emergence of lithium-ion batteries in the last couple of decades has been quite phenomenal. More than 50% of the consumer market has adopted the use of lithium-ion batteries. Particularly, laptops, mobile phones, cameras, etc. are the largest applications of lithium-ion batteries.





Lithium-ion batteries have significantly high energy density, high specific energy and longer cycle life. Other main advantages of lithium-ion batteries are slow self-discharge rate and wide range of operating temperatures.

### **Battery applications**

In the last few decades, the usage of small sealed batteries in consumer applications has been exponential. Primary or rechargeable batteries in small form factor are being used in a huge number of appliances. Some of them are mentioned below.

- Portable Electronic Devices: Watches, cameras, mobile phones, laptops, camcorders, calculators, testing equipment (multimeters).
- Entertainment: Radios, MP3 players, CD Players, all infrared remote controls, toys, games, keyboards.
- Household: Clocks, alarms, smoke detectors, flash lights, UPS, emergency lights, tooth brushes, hair trimmers and shavers, blood pressure monitors, hearing aids, pacemakers, portable power tools (drills, screw driver).

### **How to choose a battery?**

Selecting a battery for your application can be dialed down to just two characteristics: Performance and cost. But if we dig a little bit deeper, then the following are determining factors in choosing the right battery for your application.

- Primary or Secondary
- Energy or Power
- Shelf Life
- Energy efficiency and recharge rate
- Battery life
- Battery temperature

## Conclusion

This was a brief introduction to battery, different types of batteries, primary and secondary batteries, rechargeable and non-rechargeable batteries and also few common applications of each type of battery

## Lead acid battery

**Definition:** The battery which uses sponge lead and lead peroxide for the conversion of the chemical energy into electrical power, such type of battery is called a lead acid battery. The lead acid battery is most commonly used in the power stations and substations because it has higher cell voltage and lower cost.

## Construction of Lead Acid Battery

The various parts of the lead acid battery are shown below. The container and the plates are the main part of the lead acid battery. The container stores chemical energy which is converted into electrical energy by the help of the plates.

**1. Container** – The container of the lead acid battery is made of glass, lead lined wood, ebonite and hard rubber of bituminous compound, ceramic materials or molded plastic are seated at the top to avoid the discharge of electrolyte. At the bottom of the container, there are four ribs, on two of them rest the positive plate and the others support the negative plates.

The prism serves as the support for the plates and at the same time protect them from a short-circuit. The material of which the battery containers are made should be resistant to sulfuric acid, should not deform or porous, or contain impurities which damage the electrolyte.

**2. Plate** – The plate of the lead-acid cell is of diverse design and they all consist some form of a grid which is made up of lead and the active material. The grid is essential for conducting the electric current and for distributing the current equally on the active material. If the current is not uniformly distributed, then the active material will loosen and fall out.

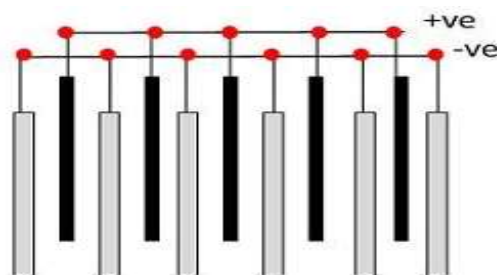

Arrangements of Plates in a Lead-acid-Battery  
Circuit Globe

The grids are made up of an alloy of lead and antimony. These are usually made with the transverse rib that crosses the plates at a right angle or diagonally. The grid for the positive and negative plates are of the same design, but the grids for the negative plates are made lighter because they are not as essential for the uniform conduction of the current.

The plates of the battery are of two types. They are the formed plates or plante plates and pasted or faure plates.

Plante's plates are used largely for stationary batteries as these are heavier in weight and more costly than the pasted plates. But the plates are more durable and less liable to lose active material by rapid charging and discharging. The plantes plate has low capacity weight-ratio.

Faure process is much suitable for manufacturing of negative plates rather than positive plates. The negative active material is quite tough, and it undergoes a comparatively low change from charging and discharging.

**3. Active Material** – The material in a cell which takes active participation in a chemical reaction (absorption or evolution of electrical energy) during charging or discharging is called the active material of the cell. The active elements of the lead acid are

**1. Lead peroxide ( $\text{PbO}_2$ )** – It forms the positive active material. The  $\text{PbO}_2$  are dark chocolate broom in colour

**2. Sponge lead** – Its form the negative active material. It is grey in colour

**3. Dilute Sulfuric Acid ( $\text{H}_2\text{SO}_4$ )** – It is used as an electrolyte. It contains 31% of sulfuric acid

The lead peroxide and sponge lead, which form the negative and positive active materials have the little mechanical strength and therefore can be used alone.

**4. Separators** – The separators are thin sheets of non-conducting material made up of chemically treated leadwood, porous rubbers, or mat of glass fibre and are placed between the positive and negative to insulate them from each other. Separators are grooved vertically on one side and are smooth on the other side.

**5. Battery Terminals** – A battery has two terminals the positive and the negative. The positive terminal with a diameter of 17.5 mm at the top is slightly larger than the negative terminal which is 16 mm in diameter.

#### **Working Principle of Lead Acid Battery**

When the sulfuric acid dissolves, its molecules break up into positive hydrogen ions ( $2\text{H}^+$ ) and sulphate negative ions ( $\text{SO}_4^-$ ) and move freely. If the two electrodes are immersed in solutions and

connected to DC supply then the hydrogen ions being positively charged and moved towards the electrodes and connected to the negative terminal of the supply. The  $\text{SO}_4^-$  ions being negatively charged moved towards the electrodes connected to the positive terminal of the supply main (i.e., anode).

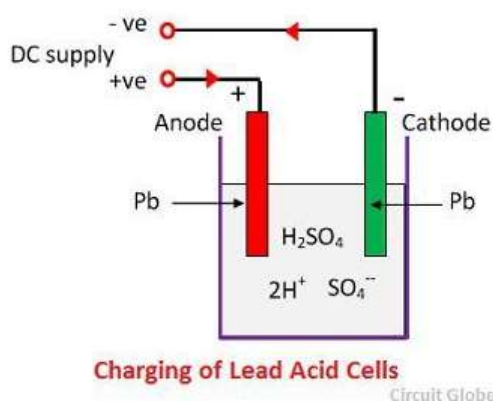

Each hydrogen ion takes one electron from the cathode, and each sulphates ions takes the two negative ions from the anodes and react with water and form sulfuric and hydrogen acid.

The oxygen, which produced from the above equation react with lead oxide and form lead peroxide ( $\text{PbO}_2$ .) Thus, during charging the lead cathode remain as lead, but lead anode gets converted into lead peroxide, chocolate in colour.

If the DC source of supply is disconnected and if the voltmeter connects between the electrodes, it will show the potential difference between them. If wire connects the electrodes, then current will flow from the positive plate to the negative plate through external circuit i.e. the cell is capable of supplying electrical energy.

### **Chemical Action during Discharging**

When the cell is full discharge, then the anode is of lead peroxide ( $\text{PbO}_2$ ) and a cathode is of metallic sponge lead (Pb). When the electrodes are connected through a resistance, the cell discharge and electrons flow in a direction opposite to that during charging.

The hydrogen ions move to the anode and reaching the anodes receive one electron from the anode and become hydrogen atom. The hydrogen atom comes in contacts with a  $\text{PbO}_2$ , so it attacks and forms lead sulphate ( $\text{PbSO}_4$ ), whitish in colour and water according to the chemical equation.

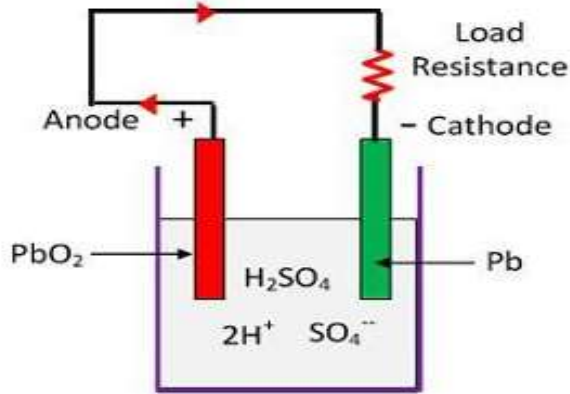
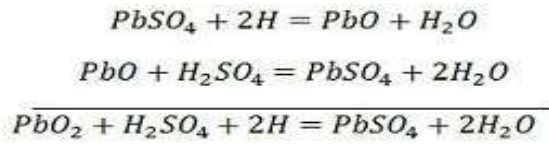

**Discharging of Lead Acid Cells**

The each sulphate ion ( $SO_4^-$ ) moves towards the cathode and reaching there gives up two electrons becomes radical  $SO_4$ , attack the metallic lead cathode and form lead sulphate whitish in colour according to the chemical equation.

**Chemical Action during Recharging**

For recharging, the anode and cathode are connected to the positive and the negative terminal of the DC supply mains. The molecules of the sulfuric acid break up into ions of  $2H^+$  and  $SO_4^-$ . The hydrogen ions being positively charged moved towards the cathodes and receive two electrons from there and form a hydrogen atom. The hydrogen atom reacts with lead sulphate cathode forming lead and sulfuric acid according to the chemical equation.

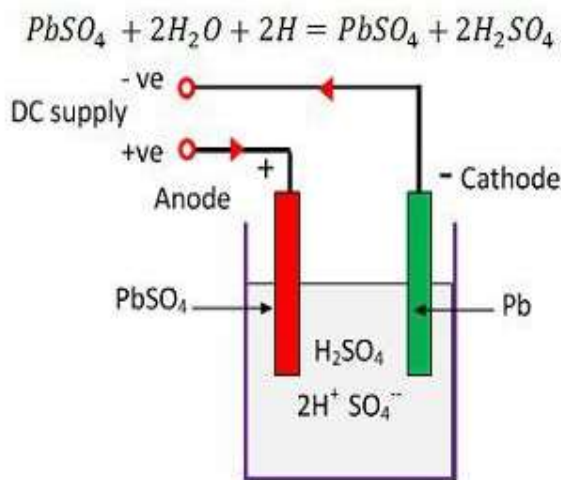

**Recharging of Lead Acid Cell**

Circuit Globe

$\text{SO}_4^-$  ion moves to the anode, gives up its two additional electrons becomes radical  $\text{SO}_4$ , react with the lead sulphate anode and form leads peroxide and lead sulphuric acid according to the chemical equation.

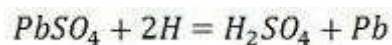

The charging and discharging are represented by a single reversible equation given below.

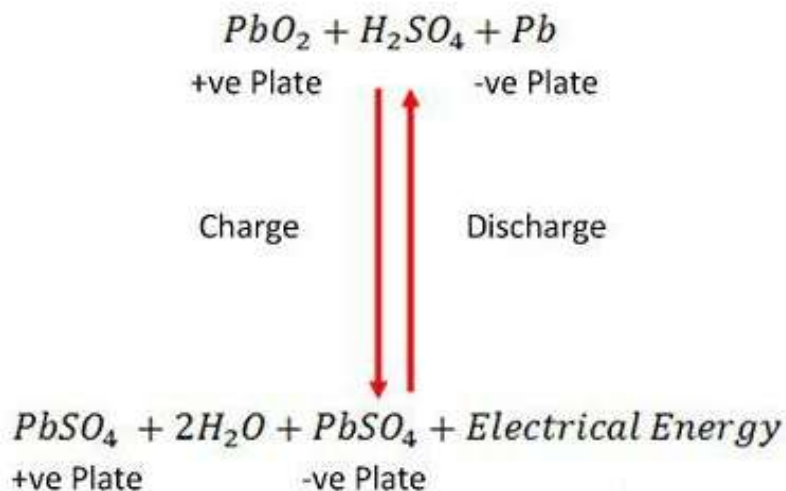

The equation should read downward for discharge and upward for recharge.

**Result:**

Physical demonstration of battery is completed.

## 2. Testing of lead acid battery

**Aim:** Testing of lead acid battery

**Procedure :**

There are no shortages of battery testers, but most lack accuracy. Capacity, the leading health indicator of a battery, is difficult to obtain on the fly. Stating that a battery tester measuring internal resistance will also provide capacity estimation is misleading. Advertising features that are outside the equipment's capabilities confuses the industry into believing that complex tests can be done with basic methods. Resistance-based instruments can identify a dying or dead battery — so does the user. Vendors often overstate the ability of battery testers knowingly. This is similar to promoting a shampoo that promises to grow lush hair on a man's bald head.

Without reliable test devices on hand, battery testing becomes guesswork, resulting in good packs being replaced too soon and passing weak ones, only to have them fail on the road soon after checking. Lack of accurate battery testing also causes unnecessary replacements under the battery warranty program. Examining warranty returns reveals that less than 10 percent of these batteries have a manufacturing fault. Most faults are user-inflicted.

The challenge arises when assessing a battery as part of routine service before performance degradations are noticeable. Such a test is only effective when including capacity measurement. Capacity oversees the energy storage, governs the runtime and predicts the end-of-life. Internal resistance, on the other hand, is responsible for the power to crank the engine and deliver high current under load on demand. A snapshot taken with a CCA tester on a starter battery refers to the resistive battery condition only. Better electrolytes and corrosion-resistant electrode materials are keeping the resistance on modern batteries low through most of their life. Failure due to elevated resistance has become rare and may only develop at the end-of-life.

Unlike voltage, current and ohmic measurements, no universal instrument exists that can read the capacity of every battery that comes along. There are three common testing concepts: Scalar, vector and EIS with complex modeling (Spectro™).

Scalar is the simplest of the three. It takes a battery reading and compares it with a reference that is often a resistive value. Most single-frequency AC conductance testers measuring CCA are based on the scalar concept.

The vector method applies signals of different currents or it excites the battery with varied frequencies, and then evaluates the results against preset vector points to study the battery under various stress conditions. This adds complexity and the added benefits are marginal.



Spectro™ scans the battery with a frequency spectrum, as if to capture the topography of a landscape, and compares the imprint with a matrix to estimate battery capacity, CCA and SoC. Spectro™ promises the most in-depth battery analysis, but it is also the most complex. Table 1 summarizes the three battery test methods.

TYPE	EXCITATION	APPLICATIONS	RESULTS
<b>Scalar</b>	Single reference point; pulses or single-frequency excitation	Automotive, stationary; simple, commonly used	Voltage, CCA, internal resistance, no capacity
<b>Vector</b>	Multiple frequencies, currents; compares against vector	Automotive, stationary; less commonly used	As above. More complex with marginal gain
<b>Spectro™</b>	Combines EIS with complex modeling; fuses data to derive at capacity, CCA, SoC	Lead- and lithium-based batteries	Provides CCA, capacity and SoC with appropriate matrices

**Table 1: Methods of data collection for battery rapid-testing**

The table compares scalar, vector and Spectro™ which combines electrochemical impedance spectroscopy (EIS) with complex modelling.

**Matrix**

A matrix is a multi-dimensional look-up table against which readings are compared. Text recognition, fingerprint identification and visual imaging operate on a similar principle. In battery analysis, matrices are primarily used to estimate capacity; however, CCA and state-of-charge also benefit from using a matrix. Spectro™ correctly predicts 8 out of 10 batteries on capacity and 9 out of 10 on CCA. Combining these two classifications provides significant improvement in test accuracies over units measuring only CCA. Most resistance-based testers deliver state-of-health predictions that are not much better than 5 correct in 10, results that can be compared with tossing a coin. Many service technicians are unaware of the low prediction rate as lab verifications are seldom done.

There is a desire for higher accuracies, but a battery can only be diagnosed if measurable symptoms are present. While packs pulled from the field give the most reliable results, outliers often lack formatting or had been in prolonged storage. To also test these batteries with certainty, matrices can be developed that include the anomalies.

State-of-charge also plays an important role, and the tester must distinguish between low charge and low capacity. Both conditions lower battery performance and are difficult to identify. Most battery testers work down to 70 percent SoC; Spectro™ goes down to 60 percent.

Creating a matrix involves scanning many batteries at different state-of-health levels. The more batteries included in the mix that are the same model but have different capacity losses, the stronger the matrix will become. A well-developed matrix should include naturally-aged battery samples with capacities ranging from 50 to 100 percent. An analogy is a bridge with many pillars to eliminate weak spots.

The population should also include batteries from hot and cold climates and different uses. For example, an aging starter battery in a Las Vegas taxi will show different symptoms than the battery in grandma's car in northern Germany used only to take her grandchildren for a ride.

Obtaining faded batteries is difficult. Forced aging by cycling in an environmental chamber is of some help, but age-related stresses are not presented accurately and the learned symptoms can fool the system. This is especially visible with Li-ion batteries. Although the capacity is down, the Nyquist plot does not follow the signature of natural aging as part of daily usage.

A generic matrix is most practical as it serves a group of batteries. Generic matrices for the Spectro™ system are available for most car batteries; the user simply enters the capacity and CCA ratings. Instead of a numeric readout, the generic matrix provides pass/fail classification based on a capacity threshold. This solution is acceptable for most service personnel as the instrument makes the decision, eliminating uncertainties and customer interference.

**Result:**

Testing of lead acid battery is completed.

### 3. Charging of lead acid battery

**Aim:** Charging of lead acid battery

**Procedure:**

#### Lead-acid battery charging methods

The lead-acid battery stores chemical energy and this energy is converted into electrical energy whenever requires. The conversion of energy from chemical to electrical is known as the charging. And when the electric power changes into chemical energy then it is known as discharging of the battery. During the charging process, the current passes inside the battery because of chemical changes. The lead-acid battery mainly uses two types of charging methods namely the constant voltage charging and constant current charging.

#### Constant voltage charging

It is the most common method of charging the lead acid battery. It reduces the charging time and increases the capacity up to 20%. But this method reduces the efficiency by approximately 10%.

In this method, the charging voltage is kept constant throughout the charging process. The charging current is high in the beginning when the battery is in the discharge condition. The current is gradually dropping off as the battery picks up charge resulting in increase back emf.

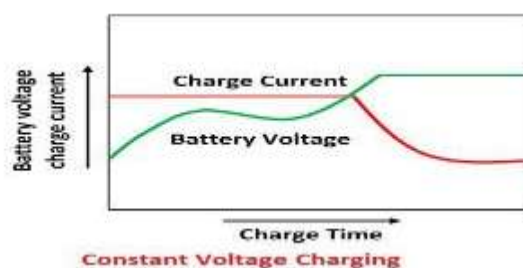

The advantages of charging at constant voltage are that it allows cells with different capacities and at the different degree of discharge to be charges. The large charging current at the beginning of the charge is of relatively short duration and will not harm the cell.

At the end of the charge, the charging current drops to almost zero because the voltage of the battery becomes nearly equal to the voltage of the supply circuit.

#### Constant Current Charging

In this method of charging the batteries are connected in series so as to form groups and each group charges from the DC supply mains through loading rheostats. The number of charging in each group depends on the charging circuit voltage which should not be less than the 2.7 V per cell.

The charging current is kept constant throughout the charging period by reducing the resistance in the circuit as the battery voltage goes up. In order of avoiding excessive gassing or overheating, the charging may be carried out in two steps. An initial charging is approximately higher current and a finishing rate of low current.

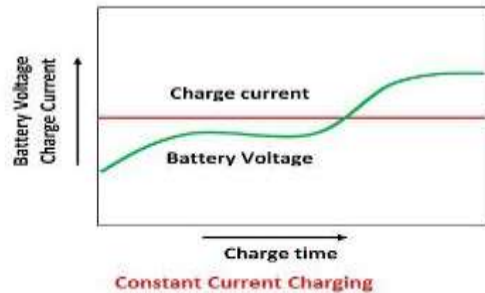

In this method, the charge current is approximately one-eighth of its ampere ratings. The excess voltage of the supply circuit is absorbed in the series resistance. The groups of the battery to be charged should be so connected that the series resistance consumes as little energy as possible.

The current carrying capacity of series resistance should be greater than or equal to the required charging current otherwise, the resistance will overheat and burn out.

The group of batteries which is to be selected should have the same capacity. If the battery has a different capacity, then they will have to be set according to the least capacity.

**Battery Charging Circuit:**

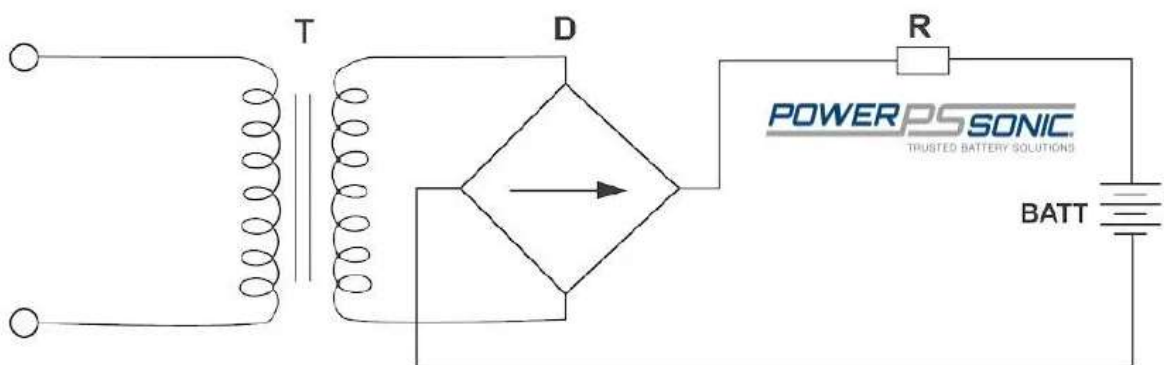

- T: Transformer
- D: Diode Rectifier
- R: Regulator

**Result:**

Charging of lead acid battery is completed.